

| 129CP SERIES

SMART WATER PRESSURE SENSOR

Utilizing Sensata’s industry leading ceramic capacitive technology, the 129CP pressure sensor is housed in a small and innovative package ideal for use in tight spaces. The sensor is robust and reliable to withstand harsh conditions such as water hammer over the life of the sensor and the water pressure sensor uses state of the art electronics to accommodate digital I²C output, low power consumption, fast response time, and end-of-conversion interrupt.

For ease of integration, the flex tail is connected to the PCB and the sensor pressure port is just compressed to an orifice where the water pressure is to be read. The 129CP is ideal for water and other mid pressure applications where low power consumption is essential like use in smart water meters.



Features

- 0-16 bar (0-232 psi) sealed gauge
- 0-230 psi sealed gauge
- Digital I²C output
- Very low power consumption (<6 μ A) at 1Hz measurement
- Small size (18 mm x 23.5 mm x 12.5 mm)
- Easy design integration
- Robust and reliable design
- Compatible with drinking water safe application

Applications

- Residential water meters
- Water networks

● SPECIFICATIONS

Electrical

Supply Voltage	1.7-3.6 VDC
Digital Output	I ² C
Resolution	14 bit min
Supply Current: Update Mode	750 to 1100 μ A
Supply Current: Sleep Mode	0.07 to 1 μ A
Wake-Up Response Time	0.5 ms max
Reverse Voltage	-0.3 VDC
ESD	IEC 61000-4-2
Radiated Immunity	IEC 61000-4-3
Electrical Connection	Flex cable (see dimensions section below)
ESD	Conforms to IEC 61000-4-2 Level 3, 4kV contact / 8kV air

Physical

Pressure Range	0 - 16 bar (0-232 psi)
Pressure Reference	Sealed Gauge
Proof Pressure	2X FS ⁽¹⁾ Pressure
Burst Pressure	5X FS ⁽¹⁾ Pressure
Accuracy (Best Fit Straight Line)⁽²⁾	+/-1%FS ⁽¹⁾ , 25°C
Accuracy (Total Error Band)⁽³⁾	+/-2% FS ⁽¹⁾ , 4 to 40°C
Fluid Compatibility*	Potable Water
Wetted Materials	Sense Element: 96%Alumina (Al2O3) Pressure Port: 304L Stainless Steel Inner Seal: EPDM Outer Seal: EPDM

*Other fluid compatibility available upon request

Performance

Random Vibration	DIN IEC 60068-2-27: 5G (2-2kHz)
Mechanical Shock	DIN IEC 60068-2-6: 40G1/2 HL SINE
Operating Temperature	2°C to 85°C
Storage Temperature	-25°C to 85°C
Waterhammer	100K cycles 0 to 25 bar (0 to 360 psi)
Operational Pressure Cycling	1M

DIMENSIONS

Dimensions in mm

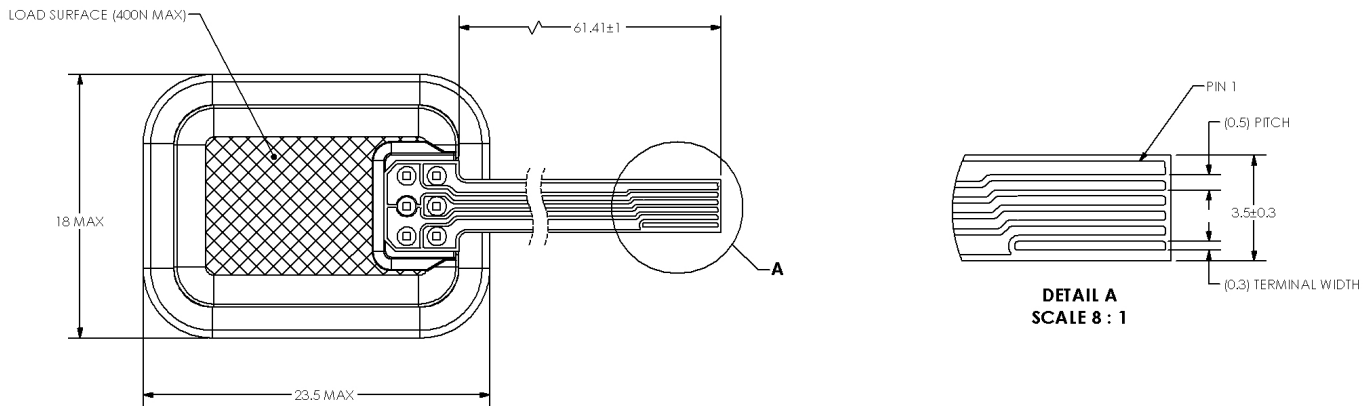

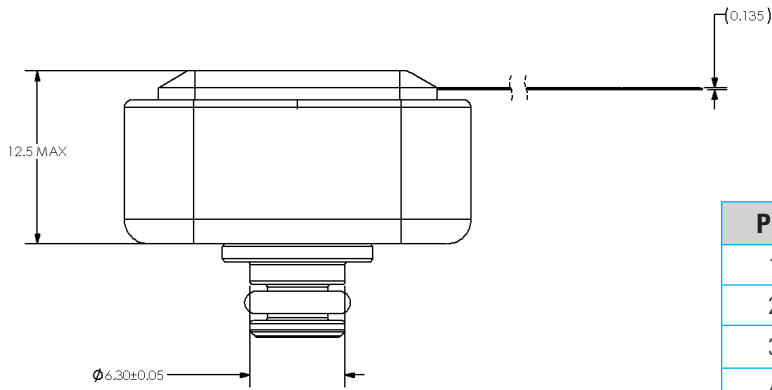

Pin	Designation	Description
1	EOC	End-of-conversion and Output Interrupt
2	GND	Ground
3	SDA	Bi-directional data for I ² C
4	SCL	Clock input for I ² C interface
5	VDD	Power supply
6	n.c.	No connection

GENERAL NOTES

- (1) Full Scale Pressure = Pmax - Pmin
- (2) Best fit straight line accuracy includes errors from non-linearity, non-repeatability, and hysteresis
- (3) Total error band accuracy includes errors from non-linearity, non-repeatability, hysteresis, zero offset, full span offset, and thermal effects

Sensata Technologies, Inc. ("Sensata") data sheets are solely intended to assist designers ("Buyers") who are developing systems that incorporate Sensata products (also referred to herein as "components"). Buyer understands and agrees that Buyer remains responsible for using its independent analysis, evaluation and judgment in designing Buyer's systems and products. Sensata data sheets have been created using standard laboratory conditions and engineering practices. Sensata has not conducted any testing other than that specifically described in the published documentation for a particular data sheet. Sensata may make corrections, enhancements, improvements and other changes to its data sheets or components without notice.

Buyers are authorized to use Sensata data sheets with the Sensata component(s) identified in each particular data sheet. HOWEVER, NO OTHER LICENSE, EXPRESS OR IMPLIED, BY ESTOPPEL OR OTHERWISE TO ANY OTHER SENSATA INTELLECTUAL PROPERTY RIGHT, AND NO LICENSE TO ANY THIRD PARTY TECHNOLOGY OR INTELLECTUAL PROPERTY RIGHT, IS GRANTED HEREIN. SENSATA DATA SHEETS ARE PROVIDED "AS IS". SENSATA MAKES NO WARRANTIES OR REPRESENTATIONS WITH REGARD TO THE DATA SHEETS OR USE OF THE DATA SHEETS, EXPRESS, IMPLIED OR STATUTORY, INCLUDING ACCURACY OR COMPLETENESS. SENSATA DISCLAIMS ANY WARRANTY OF TITLE AND ANY IMPLIED WARRANTIES OF MERCHANTABILITY, FITNESS FOR A PARTICULAR PURPOSE, QUIET ENJOYMENT, QUIET POSSESSION, AND NON-INFRINGEMENT OF ANY THIRD PARTY INTELLECTUAL PROPERTY RIGHTS WITH REGARD TO SENSATA DATA SHEETS OR USE THEREOF.

All products are sold subject to Sensata's terms and conditions of sale supplied at www.sensata.com SENSATA ASSUMES NO LIABILITY FOR APPLICATIONS ASSISTANCE OR THE DESIGN OF BUYERS' PRODUCTS. BUYER ACKNOWLEDGES AND AGREES THAT IT IS SOLELY RESPONSIBLE FOR COMPLIANCE WITH ALL LEGAL, REGULATORY AND SAFETY-RELATED REQUIREMENTS CONCERNING ITS PRODUCTS, AND ANY USE OF SENSATA COMPONENTS IN ITS APPLICATIONS, NOTWITHSTANDING ANY APPLICATIONS-RELATED INFORMATION OR SUPPORT THAT MAY BE PROVIDED BY SENSATA.

Mailing Address: Sensata Technologies, Inc., 529 Pleasant Street, Attleboro, MA 02703, USA.

CONTACT US

Americas

+1 (800) 350 2727

sensors@sensata.com

switches@sensata.com

Europe, Middle East & Africa

+359 (2) 809 1826

pressure-info.eu@sensata.com

Asia Pacific

sales.isasia@list.sensata.com

China +86 (21) 2306 1500

Japan +81 (45) 277 7117

Korea +82 (31) 601 2004

India +91 (80) 67920890

Rest of Asia +886 (2) 27602006

ext 2808