

- ▶ **Low profile, rear hinged switch designed for improved user comfort**
- ▶ **Grey cover with Herga logo fitted on a black base**
- ▶ **Fitted to a black moulded 2 pedal base**
- ▶ **Momentary action with normally open contacts**
- ▶ **According to IEC60601 IEC/UL**

Special double-pedal version of 6226 series footswitch with IPX7 rating

Specification	
Standards/approvals	the individual Footswitch : UL file reference E353500 ANSI/AAI ES60601-1, A1:2012, C1:2009/(R) 2012 and A2:2010 (R) 2012 CSA CAN/CSA-C22.2 No 60601-1-14 IEC 60601-1 Ed 3.1 (2012) EN 60601-1:2006 & A1:2013 & A12:2014 BS EN 62368-1:2014 & A11:2017
Degree of protection	EN 60529 IPX7
Connection method	2 metres of 3-core cable
Max. electrical rating	3A 24VAC/DC
Contact configuration	Normally Open contacts
Action	Momentary
Operating temperature range	-20°C to +60°C
Body material	Thermoplastic
Weight	550 grams (including cable)
Additional information	Customized versions available (logos, cordsets, colours, guards)



**Dimensions**

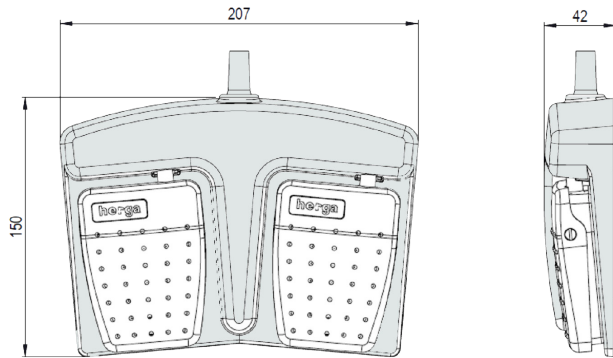

The 6226-0003 is a stock model

**Accessories**

Part Number	Description
6202-0001	Single Black RAL 9005 guard
6202-0002	Single Grey RAL 7035 guard
6202-0003	Twin Grey RAL 7035 guard

