

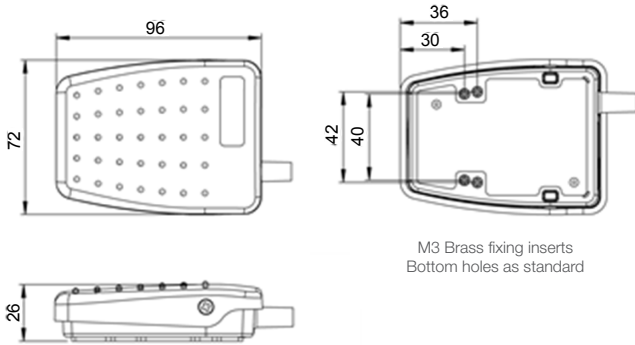

Specifications	
Standards/approvals	UL File No: E353500 · EN 60601-1:2007/A2:2021 · IEC 60601-1:2005+AMD1:2012+AMD2:2020 · CAN/CSA C22.2. No 60601-1:08 · CAN/CSA C22.2. No 60601-1-14/A1+A2:2022 · ANSI/AAMI ES60601-1:2005/A1:2012 +A2:2021
Degree of protection	EN 60529 IPX2
Connection method	Stripped cable cores, USB or connector of your choice
Electrical rating	Max. 3A 24V AC/DC
Contact configuration	SPST N/O, SPST N/C, SPCO, DPST N/O, DPST N/C, DPCO
Operating temperature range	-20 to +60°C
Body material	Thermoplastic
Weight	0.14Kg (including cable)
Additional information	Customized versions available (logos, cordsets, colours, guards)



Dimensions





Ordering information

(Please use the characters in the chart below to create your product code)

Sample Code 6225 - A A A A - A A A A - 000

Cover & base colours

- A Black Cover & Black base

- B Grey Cover & Black base

- C Yellow Cover & Black base

- D Green Cover & Black base

- L Blue Cover & Black base

- N Orange Cover & Black base

Base configuration

- A Base fitted with M3 brass inserts

- B Base fitted with Neopren pad

- C Base fitted with M3 brass inserts & Neopren pad

- D Base fitted with Anti-slip Feet

Switching action

- A Single Pole normally open microswitch (SC)

- B Single Pole change over microswitch (CC)

- C Double pole normally open microswitches (DO)

- D Double pole normally open microswitches Two changes (DA)

- E Single- or Double switch supplied without cable

- F USB Pre-programmed for customer keystroke (supplied with 2.5m cable & plug)

Electrical rating

- A Microswitch (Max, 0,1A, 24 V AC/DC)

- B Microswitch (Max, 1,75A, 24 V AC/DC)

- C Sub-Min Microswitch - for USB-Option only (Max, 20mA, 5 V AC/DC)

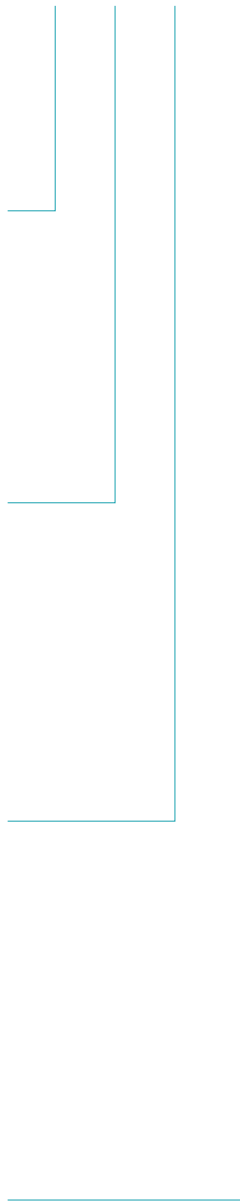

If you require a customized solution for your program contact our sales team.



Ordering information

(Please use the characters in the chart below to create your product code)

Sample Code 6225 - A A A A - A A A A - 000

IEC 60601-1 & UL 60601-1, 2-core cable at 2m length

A	Cable 2-core grey
B	Cable 2-core grey screened
C	Cable 2-core black
Z	No cable chosen

IEC 60601-1 & UL 60601-1, 3-core cable at 2m length

A	Cable 3-core grey
B	Cable 3-core grey screened
C	Cable 3-core black
Z	No cable chosen

IEC 60601-1 & UL 60601-1, 4-core cable at 2m length

A	Cable 4-core grey
B	Cable 4-core grey screened
C	Cable 4-core black
Z	No cable chosen

No cable variants - Customer fitted units (IPX2)

A	Single microswitch changeover (max. 3A, 24 V AC/DC)
B	Double microswitch changeover (max. 3A, 24 V AC/DC)
Z	No cable option chosen

special attributes

000	No special attribute
001 -	Special attribute
999	Special attribute may not be covered by UL

Accessories

Part Number	Description
6202-0001	Single black RAL 9005 guard
6202-0002	Single grey RAL 7035 guard
6202-0003	Twin grey RAL 7035 guard

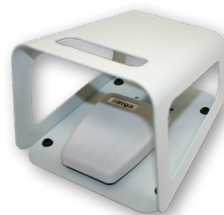

If you require a customized solution for your program contact our sales team.