

ZH03B Laser Dust Sensor Module

Profile

Laser Dust sensor module is a common type, small size sensor, using laser scattering principle to detect the dust particles in air, with good selectivity and stability. It is easy to use, with serial port output & PWM output.



Features

Good consistency, Real time response

Accurate data, Low power consumption

Minus resolution of particle diameter 0.3 μm

Main Applications

It's widely used in air purifiers, ventilation systems, portable instrument, air quality monitoring equipment, air conditioner, and smart home equipment.

Technical Parameters stable1.

Model	ZH03B
Detection diameter range	0.3~10 μm
Valid range	0~1000 $\mu\text{g}/\text{m}^3$
Detection interval	1s
PM2.5 detection accuracy	0~100 $\mu\text{g}/\text{m}^3$: $\pm 15 \mu\text{g}/\text{m}^3$ 101~1000 $\mu\text{g}/\text{m}^3$: $\pm 15\%$ reading (test conditions: 25 $\pm 2^\circ\text{C}$, 50 \pm 10%RH, TSI8530, ciggrates, GBT18801-2015)
Stabilization time after power on	30s
Output	UART_TTL OUTPUT(3.3V level, default)
	PWM output(3.3V level, default)
Working Voltage	4.9V~5.5V(DC)
Working Current	<120mA
Dormancy current	<20mA
Response Time	T_{90} <45s
Working Humidity	0~80%RH (no condensation)
Working Temperature	-10~50 $^\circ\text{C}$
Storage Temperature	-30~70 $^\circ\text{C}$
Dimension	50x32.4x21mm(LxWxH)
Weight	<38g
MTTF	Continuous without interruption>10000h

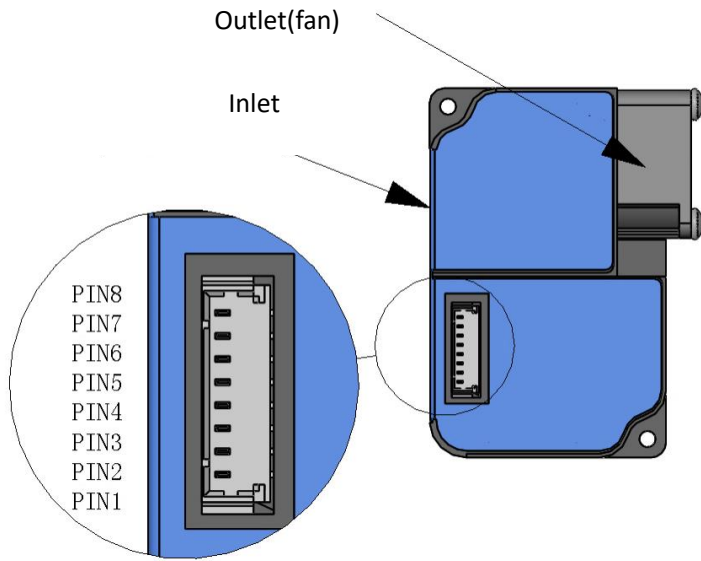

Fig1.Pins

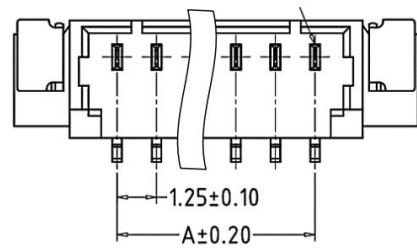
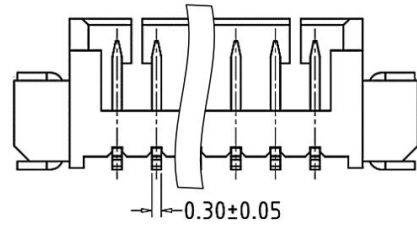

Fig2.Part no. of Pins(A=8x1.25)



Stable2.Pins definition

PIN1	VDD	DC +5V
PIN2	GND	GND
PIN3	-	NC
PIN4	RXD	Serial port receive TTL@3.3V
PIN5	TXD	Serial port send TTL@3.3V
PIN6	-	hang in air for users
PIN7	-	NC
PIN8	PWM output	TTL@3. 3V

Communication Protocol

1. General Settings

Baud rate	9600
Date byte	8 bytes
Stop byte	1 byte
Check byte	no

2. Initiative upload

No.	Instruction		Data
0	Byte 1	Start byte 1	0x42
1	Byte 2	Start byte 2	0x4D
2	Byte 3	Frame length	high 8 bits 0x00
3	Byte 4		low 8 bits 0x14
4	Byte 5	Data 1	high 8 bits Reserved
5	Byte 6		low 8 bits
6	Byte 7	Data 2	high 8 bits Reserved
7	Byte 8		low 8 bits
8	Byte 9	Data 3	high 8 bits Reserved
9	Byte 10		low 8 bits
10	Byte 11	Data 4	high 8 bits PM1.0 concentration
11	Byte 12		low 8 bits (ug/m ³)
12	Byte 13	Data 5	high 8 bits PM2.5 concentration
13	Byte 14		low 8 bits (ug/m ³)
14	Byte 15	Data 6	high 8 bits PM10 concentration
15	Byte 16		low 8 bits (ug/m ³)
16	Byte 17	Data 7	high 8 bits reserved
17	Byte 18		low 8 bits
18	Byte 19	Data 8	high 8 bits reserved
19	Byte 20		low 8 bits
20	Byte 21	Data 9	high 8 bits reserved
21	Byte 22		low 8 bits
22	Byte 23	Checksum	high 8 bits Initiative upload check
23	Byte 24		low 8 bits = byte1+.....+byte 22

NOTE:

- The default communication mode is **initiative uploading mode**.
- Take an example to explain calculate method:

Receiving the following data frames:

No.	0	1	2	3	4	5	6	7	8	9	10	11
Data	0x42	0x4D	0x00	0x14	0x00	0x54	0x00	0x6E	0x00	0x7C	0x00	0x54
No.	12	13	14	15	16	17	18	19	20	21	22	23
Data	0x00	0x6E	0x00	0x7C	0x00	0x00	0x00	0x00	0x00	0x00	0x03	0x1F

Check value=

$$0x42+0x4D+0x00+0x14+0x00+0x54+0x00+0x6E+0x00+0x7C+0x00+0x54+0x00+0x6E+0x00+0x7C+0x00+0x00+0x00+0x00+0x00+0x00+0x00 = 0x031F$$

High 8 bits 0x03 is in 23th byte of data frame, low 8 bits 0x1F is in 24th byte of data frame.

PM1.0 value=0x00*256+0x54=84ug/m³

PM2.5 value=0x00*256+0x6E=110ug/m³

PM10 value=0x00*256+0x7C=124ug/m³

The range for PM1.0, PM2.5 and PM10 are all 0-1000ug/m³.

3. Question & answer mode (Q&A mode)

Send the command:

0	1	2	3	4	5	6	7	8
Starting byte	Reserve	command	reserve	reserve	reserve	reserve	reserve	Check value
0xFF	0x01	0x86	0x00	0x00	0x00	0x00	0x00	0x79

Return value as follow:

0	1	2	3	4	5	6	7	8
Starting byte	Command	PM2.5 (ug/m ³)		PM10 (ug/m ³)		PM1.0 (ug/m ³)		Check value
		High 8 bits (ug/m ³)	Low 8 bits (ug/m ³)	High 8 bits (ug/m ³)	Low 8 bits (ug/m ³)	High 8 bits (ug/m ³)	Low 8 bits (ug/m ³)	
0xFF	0x86	0x00	0x85	0x00	0x96	0x00	0x65	0xFA

Note: The Q&A data frame check value calculation method is different from the method of initiative uploading the data frame. Please refer to the Q&A check value calculation example.

4. Switch between Q&A mode and Initiative uploading mode

Send command to set Q&A mode:

0	1	2	3	4	5	6	7	8
Starting byte	Reserve	command	Q&A	Reserve	Reserve	Reserve	Reserve	Check value
0xFF	0x01	0x78	0x41	0x00	0x00	0x00	0x00	0x46

Send command to set initiative uploading mode:

0	1	2	3	4	5	6	7	8
Starting byte	Reserve	Command	Upload	Reserve	Reserve	Reserve	Reserve	Check value
0xFF	0x01	0x78	0x40	0x00	0x00	0x00	0x00	0x47

5. Dormant mode.

Send command to set dormant mode:

0	1	2	3	4	5	6	7	8
Starting byte	Reserve	Main command	Command to be dormant	Reserve	Reserve	Reserve	Reserve	Check value
0xFF	0x01	0xA7	Enter:0x01	0x00	0x00	0x00	0x00	0x57
			Quit:0x00					0x58

Return value as follow:

0	1	2	3	4	5	6	7	8
Starting byte	Main command	Return	Reserve	Reserve	Reserve	Reserve	Reserve	Check value
0xFF	0xA7	Successful: 0x01	0x00	0x00	0x00	0x00	0x00	0x58
		Failure: 0x00						0x59

Calculate method for check value under Q&A mode:

```

unsigned char FucChecksum(unsigned char *i, unsigned char ln)
{
    unsigned char j,tempq=0;
    i+=1;
    for(j=0;j<(ln-2);j++)
    {
        tempq+=*i;
        i++;
    }
    tempq=(~tempq)+1;
    return(tempq);
}
    
```

How to calculate under Q&A mode:

If the returning data as follow:

0	1	2	3	4	5	6	7	8
Starting byte	Command	PM2.5 (ug/m3)		PM10 (ug/m3)		PM1.0 (ug/m3)		
		High 8 bits (ug/m ³)	Low 8 bits (ug/m ³)	High 8 bits (ug/m ³)	Low 8 bits (ug/m ³)	High 8 bits (ug/m ³)	Low 8 bits (ug/m ³)	Check value
0xFF	0x86	0x00	0x85	0x00	0x96	0x00	0x65	0xFA

Check value = 0x86 + 0x00 + 0x85 + 0x00 + 0x96 + 0x00 + 0x65

= 0x06 (keep low 8 bits only)

= 0xF9 (negation)

= 0xFA (plus 1)

PM1.0 value=0x00*256+0x65=101ug/m3

PM2.5 value=0x00*256+0x85=133ug/m3

PM10 value=0x00*256+0x96=150ug/m3

The range for PM1.0, PM2.5 and PM10 are all 0-1000ug/m3.

PWM output way

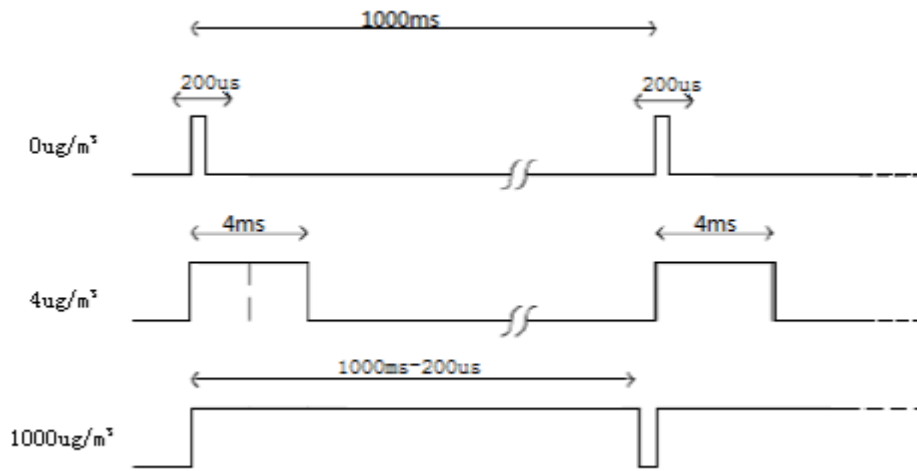

To calculate PM2.5 concentration through PWM:

$$P (\text{ug}/\text{m}^3) = 1000 \times (\text{TH}) / (\text{TH} + \text{TL})$$

P (ug/m^3) is calculated value of PM2.5 concentration, its unit is ug/m^3

TH is the time of high level during one period

TL is the time of low level during one period

PWM signal instruction

Detection Range	0-1000 ug/m^3
PWM signal voltage	3.3V-TTL default
PM2.5 concentration output range	0-1000 ug/m^3
Period	1000ms \pm 5%
High level output at the period start	200us(theoretical value)
Middle of the period	1000ms \pm 5%
Low level output at the period end	200us (theoretical value)

NOTE: PWM signal output has PM2.5 value only.

Working Principle:

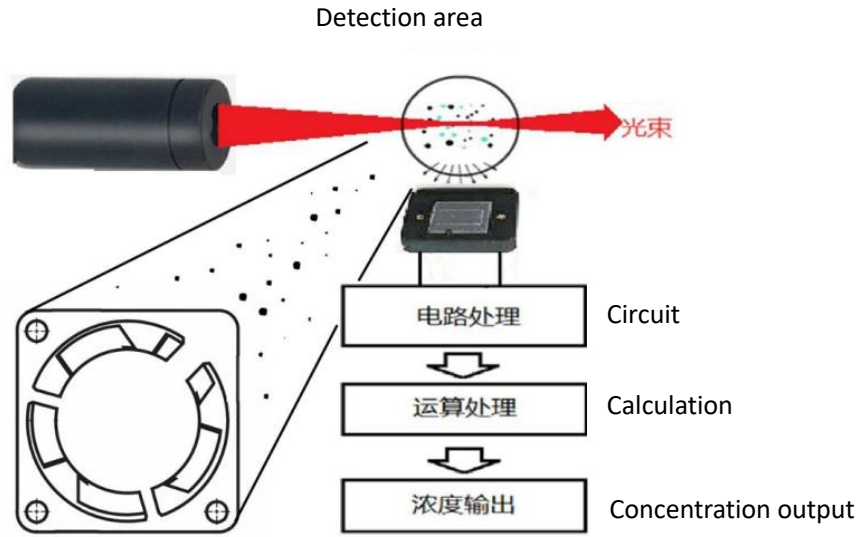

Structure and Sizes:

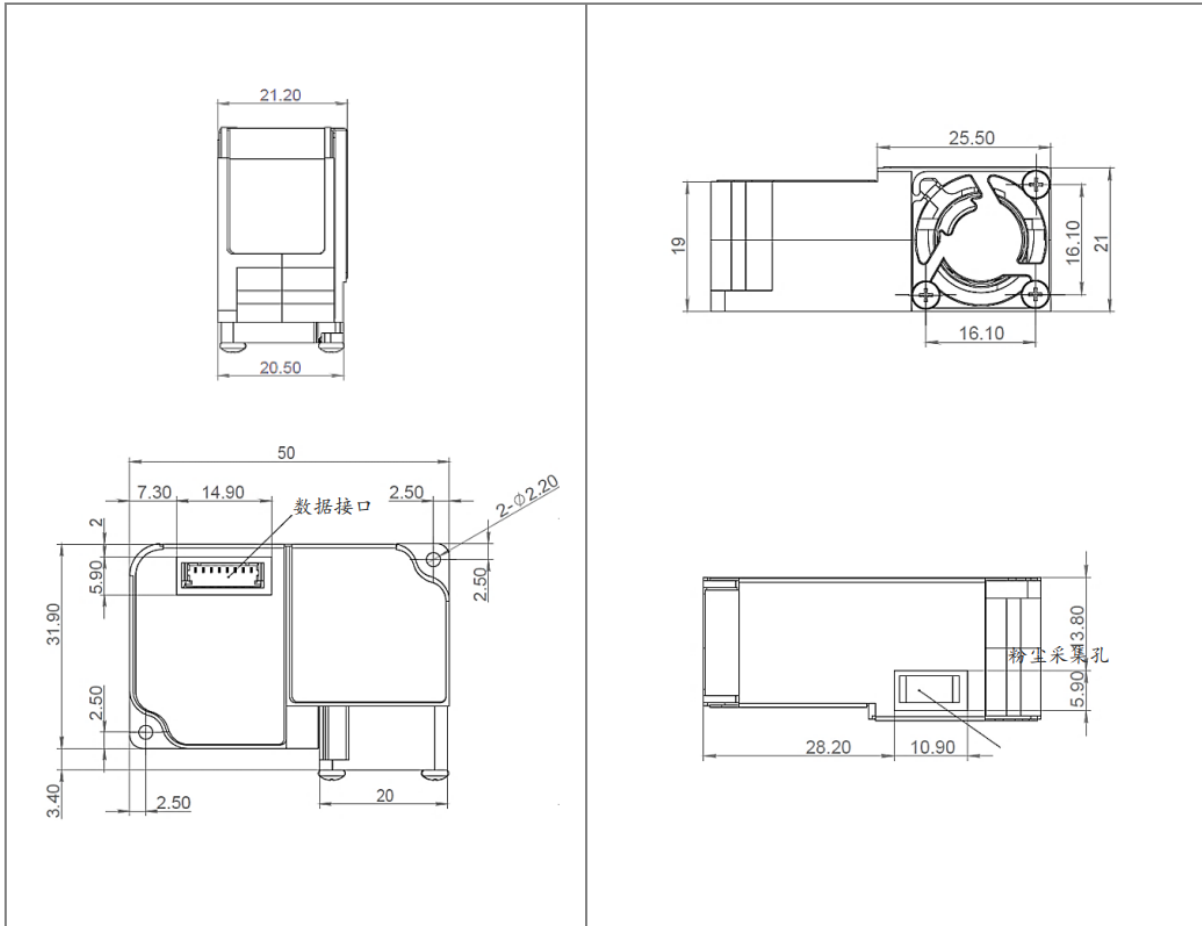

Cautions:

1. It is forbidden to disassemble the shield cover of the sensor and the fixing screw on the sensor. The sensor shield is connected to the internal power supply through internal spring, if the sensor shield is removed, the anti-interference ability of the sensor will be deteriorated and sensors' output value will jump leading that performance is degraded. It is also important to note that the sensor's metal shield should be protected from contacting with other external circuits or conductive components, to reduce the effects of external interference.
2. Excessive impact or vibration will affect the sensors' accuracy and lifespan, so the sensor should be protected from falling or vibrating during installation and use.¥
3. The sensor is suitable for the detection of dust particles in ordinary indoor environment. The actual use environment should avoid the soot environment, excessive dust particles, high humidity environment, such as: kitchen, bathroom, smoking room, outdoor environment. If used in such an environment, it should be added appropriate protective procedures to prevent viscous particles or large particles from entering the sensor and forming a reservoir inside the sensor that affects the performance of the sensor. (For example, in the environment where flocs or fibers are used, the corresponding coarse filter should be added in front of the air inlet of the sensor to avoid flocs or large debris entering the sensor and blocking the light path, thus affecting the sensors' accuracy.)
4. The fan is the air outlet, and the dust collecting hole is the air inlet. During the use of the sensor, the sensor should avoid placing directly inside the purifier's own air duct. If it is unavoidable, an independent space structure should be set for the sensor installation position. Referring to figure, the sensor should not be affected by the airflow in the direction of the red arrow. There should be no obstruction within 2cm around the air outlet of the sensor fan. In this independent space, the airflow from the sensor outlet should be prevented from flowing directly back to the air inlet, thus affecting the accuracy.
5. Under the normal working condition with normal temperature and normal pressure, the key component laser can work continuously for more than 10,000 hours. It can also increase the service life of the sensor by setting the dormancy mode and working interval. The maximum cumulative working life of the sensor can reach more than 3 years.
6. The sensor data mentioned in this manual is to ensure the consistency between the individual manufacturers of the sensor, and does not use third-party testing instruments or data as a comparison standard. If users want the final measurement result to be consistent with the third-party detection device, users can perform data fitting correction according to the actual collection result.