

## MP901 Air-Quality Gas Sensor

### Profile

MP901 gas sensor is for air quality. It adopts multilayer thick film manufacturing technology. The heater and metal oxide semiconductor material on the ceramic substrate of subminiature Al<sub>2</sub>O<sub>3</sub> are fetched out by electrode down-lead, encapsulated in metal socket and cap. Conductivity of the sensor is affected by the concentration of target gas. The higher the concentration is, the higher conductivity of sensor gets. Users can adopt simple circuit to convert variation of conductivity into output signal corresponding to gas concentration.

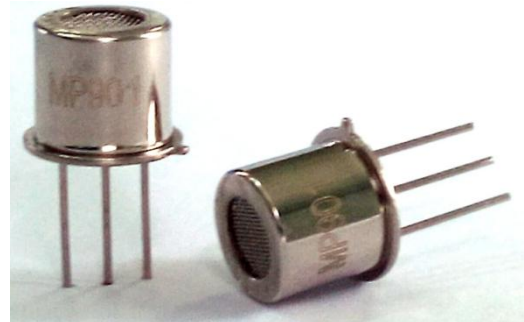

### Features

High sensitivity to alcohol, smoke, formaldehyde, toluene, acetone, benzene, lighter gas, paint; quick response and resume; low power consumption, simple detection circuit, good stability and long life.

### Main Application

It is used in occasions such as household and office for harmful gas detection, automatic exhaust device, air cleaner&etc.

### Technical Parameters Stable1.

Model			MP901
Sensor Type			Semiconductor flat surfaced sensor
Standard Encapsulation			Metal Cap
Detection Gas			alcohol, smoke, formaldehyde, toluene, acetone, benzene, lighter gas, paint &etc.
Detection range			1~50ppm
Standard circuit	Loop voltage	V <sub>C</sub> / V <sub>H</sub>	5.0V±0.1V DC
	Load resistance	R <sub>L</sub>	Adjustable
sensor features in standard test condition	Heating resistance	R <sub>H</sub>	95Ω±10Ω(Room Tem.)
	Heating consumption	P <sub>H</sub>	≤300mW
	Surface resistance	R <sub>S</sub>	1KΩ~30KΩ(in 10ppm alcohol)
	Sensitivity	S	R <sub>S</sub> (in air)/R <sub>S</sub> (in 10ppm alcohol) ≥5
	Concentration slope	α	≤0.6(R 50ppm/R 5ppm alcohol)
Standard condition of test	Temperature, humidity		20°C±2°C; 65%±5%RH
	Standard test circuit		V <sub>C</sub> /V <sub>H</sub> :5.0V±0.1V
	Warm-up time		More than 48 hours

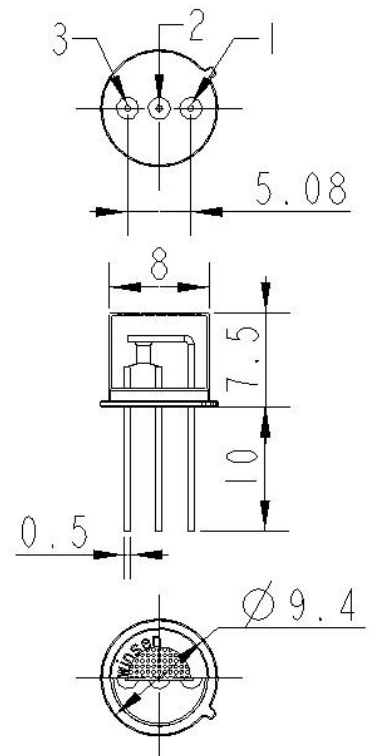

Fig1. Sensor Structure

**Basic Circuit**

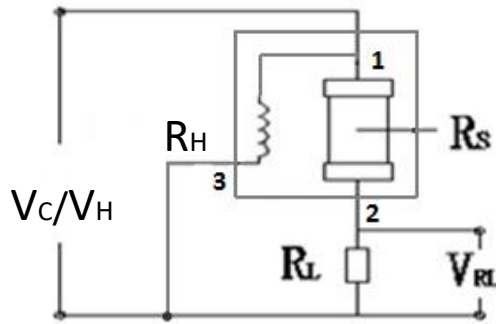

Fig2. MP901 Test Circuit

**Instructions:** The above fig is the basic test circuit of MP901. The sensor requires heater voltage ( $V_H$ ) and circuit voltage ( $V_C$ ) which share one source. They must adopt DC power.  $V_{RL}$  is the voltage of load resistance  $R_L$  which is in series with sensor.

**Description of Sensor Characters**

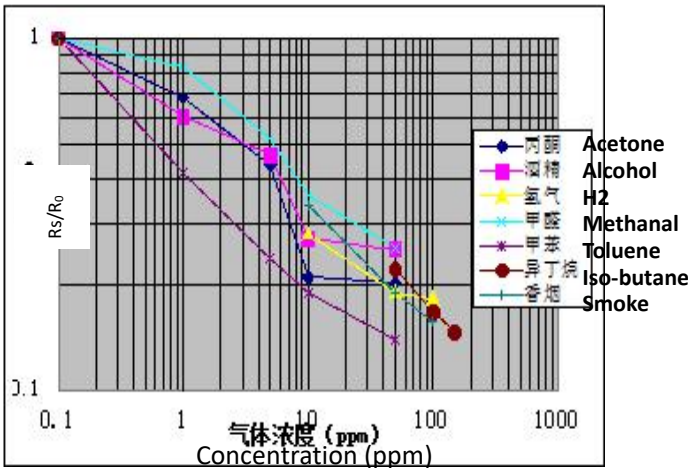

Fig3. Typical Sensitivity Curve

$R_s$  means resistance in target gas with different concentration,  $R_0$  means resistance of sensor in clean air. All tests are finished under standard test conditions.

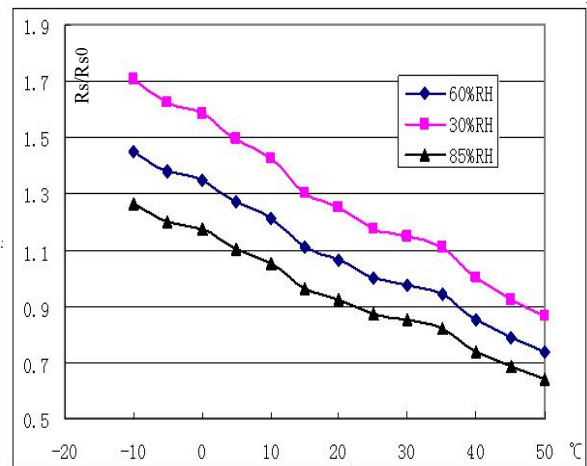

Fig4. Typical temperature/humidity characteristics

$R_s$  means resistance of sensor in 10ppm alcohol under different tem. and humidity.  $R_{s0}$  means resistance of the sensor in 50ppm alcohol under  $20^{\circ}C/55\%RH$ .

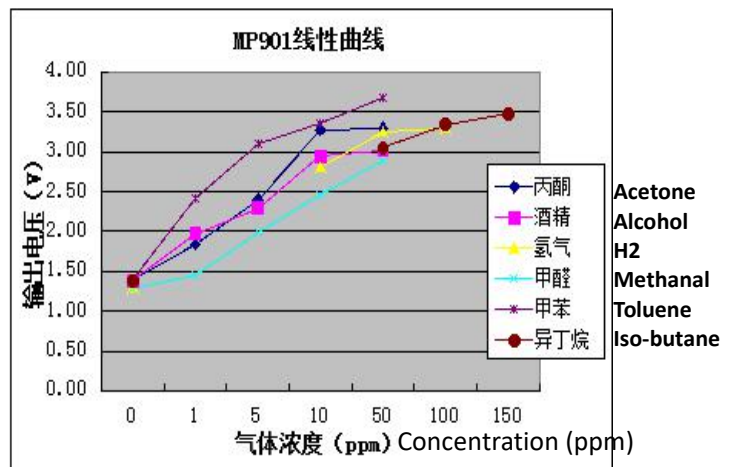
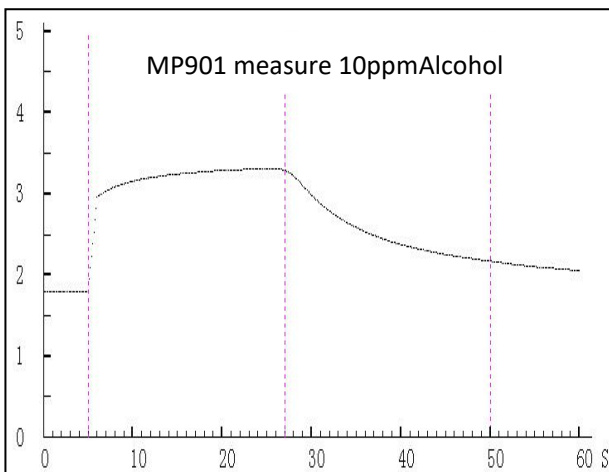

Fig5.Responce and Resume

Fig6.Linearity curve

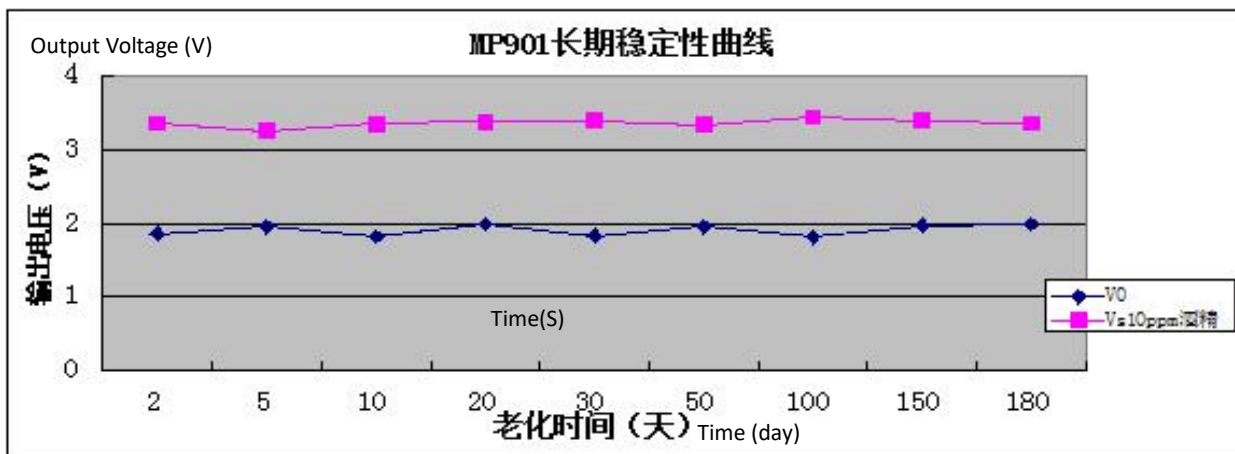

Fig7.long-term Stability of MP901

NOTE: Test is finished in standard test conditions, the abscissa is observing time and the ordinate is  $V_{RL}$ .

## Cautions

### 1. Following conditions must be prohibited

#### 1.1 Exposed to volatilizable organic silicon steam

Sensing material will lose sensitivity and never recover if the sensor absorbs organic silicon steam. Sensors must avoid exposing to silicon bond, fixture, silicon latex, putty or plastic contain silicon environment.

#### 1.2 High Corrosive gas

If the sensors are exposed to high concentration corrosive gas (such as  $H_2S$ ,  $SO_x$ ,  $Cl_2$ ,  $HCl$  etc.), it will not only result in corrosion of sensors structure, also it cause sincere sensitivity attenuation.

#### 1.3 Alkali, Alkali metals salt, halogen pollution

The sensors performance will be changed badly if sensors be sprayed polluted by alkali metals salt especially brine, or be exposed to halogen such as fluorine.

#### 1.4 Touch water

Sensitivity of the sensors will be reduced when spattered or dipped in water.

#### 1.5 Freezing

Do avoid icing on sensor's surface, otherwise sensing material will be broken and lost sensitivity.

#### 1.6 Applied higher voltage

Applied voltage on sensor should not be higher than stipulated value, even if the sensor is not physically damaged or broken, it causes down-line or heater damaged, and bring on sensors' sensitivity characteristic changed badly.

#### 1.7 Voltage on wrong pins

As Fig8, Pin 1 connects to heater(or test) power supply, Pin 2 connects to load resistance, Pin 3 connects ground.;

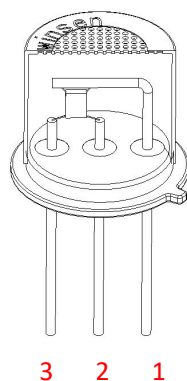
**Fig8. Pins Schematic Diagram****2 .Following conditions should be avoided****2.1 Water Condensation**

Indoor conditions, slight water condensation will influence sensors' performance lightly. However, if water condensation on sensors surface and keep a certain period, sensors' sensitive will be decreased.

**2.2 Used in high gas concentration**

No matter the sensor is electrified or not, if it is placed in high gas concentration for long time, sensors characteristic will be affected. If lighter gas sprays the sensor, it will cause extremely damage.

**2.3 Long time storage**

The sensors resistance will drift reversibly if it's stored for long time without electrify, this drift is related with storage conditions. Sensors should be stored in airproof bag without volatile silicon compound. For the sensors with long time storage but no electrify, they need long galvanical aging time for stability before using. The suggested aging time as follow:

**Stable2.**

Storage Time	Suggested aging time
Less than one month	No less than 48 hours
1 ~ 6 months	No less than 72 hours
More than six months	No less than 168 hours

**2.4 Long time exposed to adverse environment**

No matter the sensors electrified or not, if exposed to adverse environment for long time, such as high humidity, high temperature, or high pollution etc., it will influence the sensors' performance badly.

**2.5 Vibration**

Continual vibration will result in sensors down-lead response then break. In transportation or assembling line, pneumatic screwdriver/ultrasonic welding machine can lead this vibration.

**2.6 Concussion**

If sensors meet strong concussion, it may lead its lead wire disconnected.

**2.7 Usage Conditions**

2.7.1For sensor, handmade welding is optimal way. The welding conditions as follow:

- Soldering flux: Rosin soldering flux contains least chlorine
- homothermal soldering iron
- Temperature: 250°C

- Time: less than 3 seconds  
2.7.2 If users choose wave-soldering, the following conditions should be obey:
- Soldering flux: Rosin soldering flux contains least chlorine
- Speed: 1-2 Meter/ Minute
- Warm-up temperature:  $100\pm 20^{\circ}\text{C}$
- Welding temperature:  $250\pm 10^{\circ}\text{C}$
- One time pass wave crest welding machine

If disobey the above using terms, sensors sensitivity will reduce.

Zhengzhou Winsen Electronics Technology Co., Ltd

**Add:** No.299, Jinsuo Road, National Hi-Tech Zone, Zhengzhou 450001

China

**Tel:** +86-371-67169097 / 67169670 **Fax:** +86-371-60932988

**ALCYON**

ÉLECTRONIQUE

[commercial@alcyonelectronique.fr](mailto:commercial@alcyonelectronique.fr)