

# 6241 Bellow Footswitch / Palm Switch Multi-pedal version



Technology Ltd

- Multi-pedal footswitch, 1-8 pedal options
- Compact for discrete placement beneath equipment or for storage
- Robust and aesthetic design
- Soft touch buttons with a light operating force
- Ideal for motion control applications



## Reference Dimensions

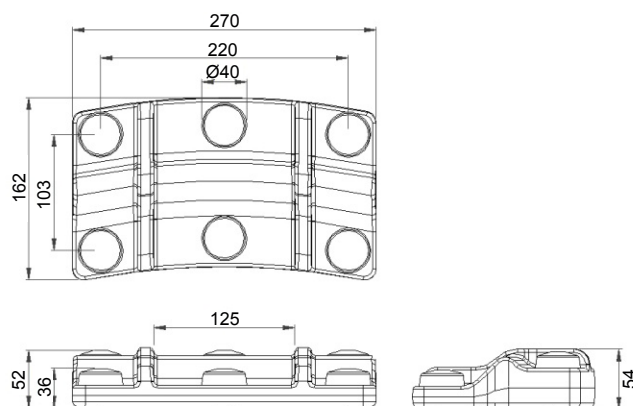

## General Specifications

Standards / Approvals	Switches: UL 60601-1, File No. E353500, IEC 60601-1
Degree of protection	EN 60529 IP67 (IP68 upon request)
Connection method	Stripped cable cores or connector of your choice, straight or curly coil cable
Electrical rating	50mA 24V DC
Contact configuration	SPST N/O

Operating and storage temperature	+ 10°C to + 50°C
Body material	Thermoplastic
Weight	1.0 kg
Additional information	choice of colours, logos and labels available

**ALCYON**  
ÉLECTRONIQUE  
[commercial@alcyonelectronique.fr](mailto:commercial@alcyonelectronique.fr)

