

Medical Footswitch Design Platform

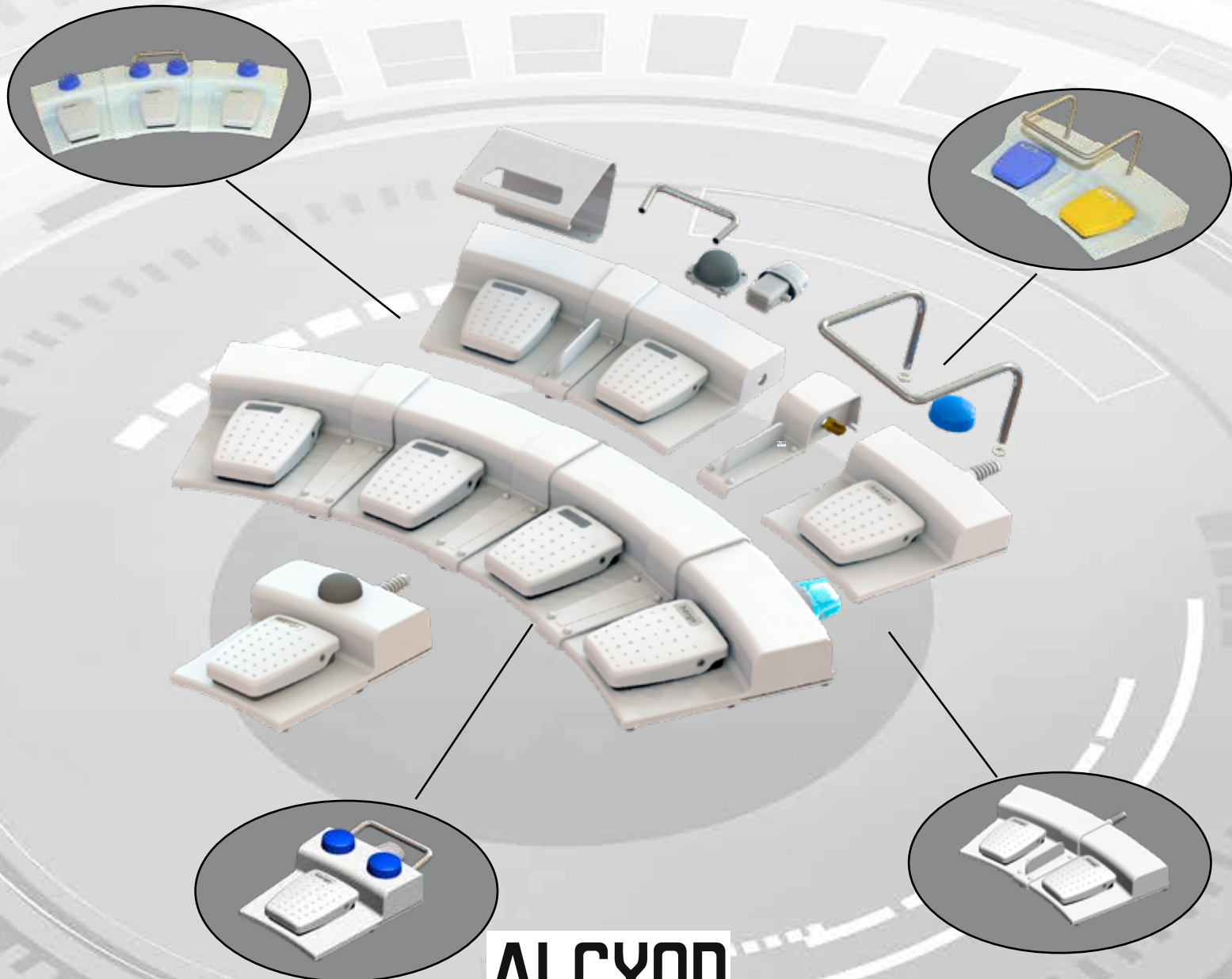

Herga

Technology Ltd



ALCYON
ÉLECTRONIQUE
commercial@alcyonelectronique.fr

SWITCHING AND SENSING SOLUTIONS

The new Medical Footswitch Design Platform

Customers can design their own footswitch platform

Herga's Medical Design Platform can combine our standard electrical footswitches and puck (bellows) switches with a variety of options and provides an aesthetic appearance within the modular base system that allows very high flexibility.

The **entire platform** successfully passed the **UL-60601 medical product approval** which means that every combination the customer chooses is automatically medically approved.

Herga is globally unique with this market leading, flexible approach for medically approved products.

Typical applications for these products are:



Laser actuation

Laser based treatments for diagnostic and therapeutic medical applications invariably involves expert manipulation with carefully coordinated hand, eye and foot operation. The Medical Footswitch Design Platform's modular capability allows medical equipment manufacturers the ability to combine electrical and Bluetooth® footswitches and puckswitches to provide durable, ergonomic foot operated controls that precisely and optimally match the techniques required for the application.



Electrosurgery

High-frequency electrosurgery equipment allows surgeons to manually perform precise and safe incisions and as part of almost every type of surgical procedure. Where penlight or tweezer type devices are used, the surgeon's control and synchronisation of the HF energy for both cutting and coagulation is critical to the process. Herga's Medical Footswitch Design Platform addresses this need with ergonomic and fully modular electrical and Bluetooth® footswitch solutions that are sturdy and robust – and designed for and in full compliance for use in the operating theatre.

Entire platform with UL-60601 approval

OEMs can easily accommodate their specific switching requirements for a single machine or range of machines with varying functionality.

The modular base allows the implementation of a variety of options and provides an aesthetic appearance within the device family. Sealing options are IPX7 and IPX8.

Operating tables and chairs

For the operating theatre where the proximity of both the surgical team and the patient needs to be perfectly arranged for comfort, safety and optimal results, the precise and simplified controls of Herga's Medical Footswitch Design Platform allows the table positions, pressure adjustments and other critical functions to be effortlessly switched during surgical procedures - hands-free from a single modular unit without the encumbrance of hand controls.



Non-invasive surgery

As more and more non-invasive surgical techniques such as arthroscopy and laparoscopy evolve, the function of the endoscope and the associated instruments becomes increasingly multifaceted. A surgeon's dexterity for these amazing key-hole surgery techniques relies on precise hand to eye coordination and Herga's Medical Footswitch Design Platform can provide a great asset for controlling and actuating complementary processes. The modular design means that designers of such systems can cater for the different types of surgery with the ability to seamlessly add new features when required.



Other application areas

Include image capturing (X-Ray, MRI, CT) ophthalmology and dentistry apparatus, cosmetic and plastic surgery equipment and other diagnostic and therapeutic patient support equipment.

Please contact us to discuss your specific application.

Standards and approvals

Standards and approvals for the Medical Footswitch Design Platform

Herga Technology is proud that its Modular Base System has successfully gained UL- and IEC- 60601-1 medical product approval and will now be launched as the new **Medical Footswitch Design Platform**. In combination with Herga's best-in-class medically approved electrical and Bluetooth® footswitches, bellow footswitches and puckswitches, this building-block platform now provides a globally unique solution for multipedal medical equipment footswitch selection and purchase. With the **Medical Footswitch Design Platform**, OEMs can be assured their complete multipedal switching module has medical approval on delivery.



Standards and approvals

The MD series footswitch is an accessory for use with electrical equipment and is designed and approved to General Medical Electrical Equipment Standards:

- EN 60601-1:2006+A12:2014
- IEC 60601-1:2005+A1:2012
- CAN/CSA C22.2 No 60601-1-14ANSI/AAMI ES60601-1:2005

General Specifications

IP rating: IPX7, IPX8 upon request

Working temperature range: -20° C to +70° C
(subject to change depending on selected options)

Material: Thermoplastic

Contact configuration: SPST N/O, SPST N/C, SPDT momentary

Electrical rating: Safety Extra Low Voltage (SELV)
20mA, 50mA, 0.1A or 3A 24V AC/DC

Key product features

Base Options:

Pedal base with 6226 footswitch

The unique design impresses with both aesthetics and functionality. Seamless range expansion is easily accommodated. Thanks to the modular design the footswitch base can be combined with up to five other bases and the 6226 footswitch.



The base system consists of moulded thermoplastic single and double plinths that mechanically lock with joining spacers to provide electrical connections for 1 to 5-plinth configurations.

Switch Specification

Standard Model (without cable)	Size (mm)	Weight (g)
1-Pedal	150 x 174 x 44	350
2-Pedal	322 x 188 x 48	720
3-Pedal	490 x 207 x 48	1150
4-Pedal	648 x 240 x 48	1450
5-Pedal	793 x 275 x 48	1950

Modular base

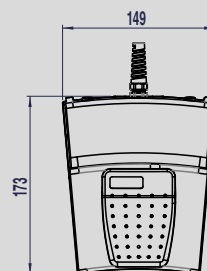

Bases and Dividers

Base Divider Options:

For improved operational safety, each footswitch may also be separated with a raised or lower divider (plastic or metal) built into the joining spacer.

Steel base plates are available for added weight / stability.

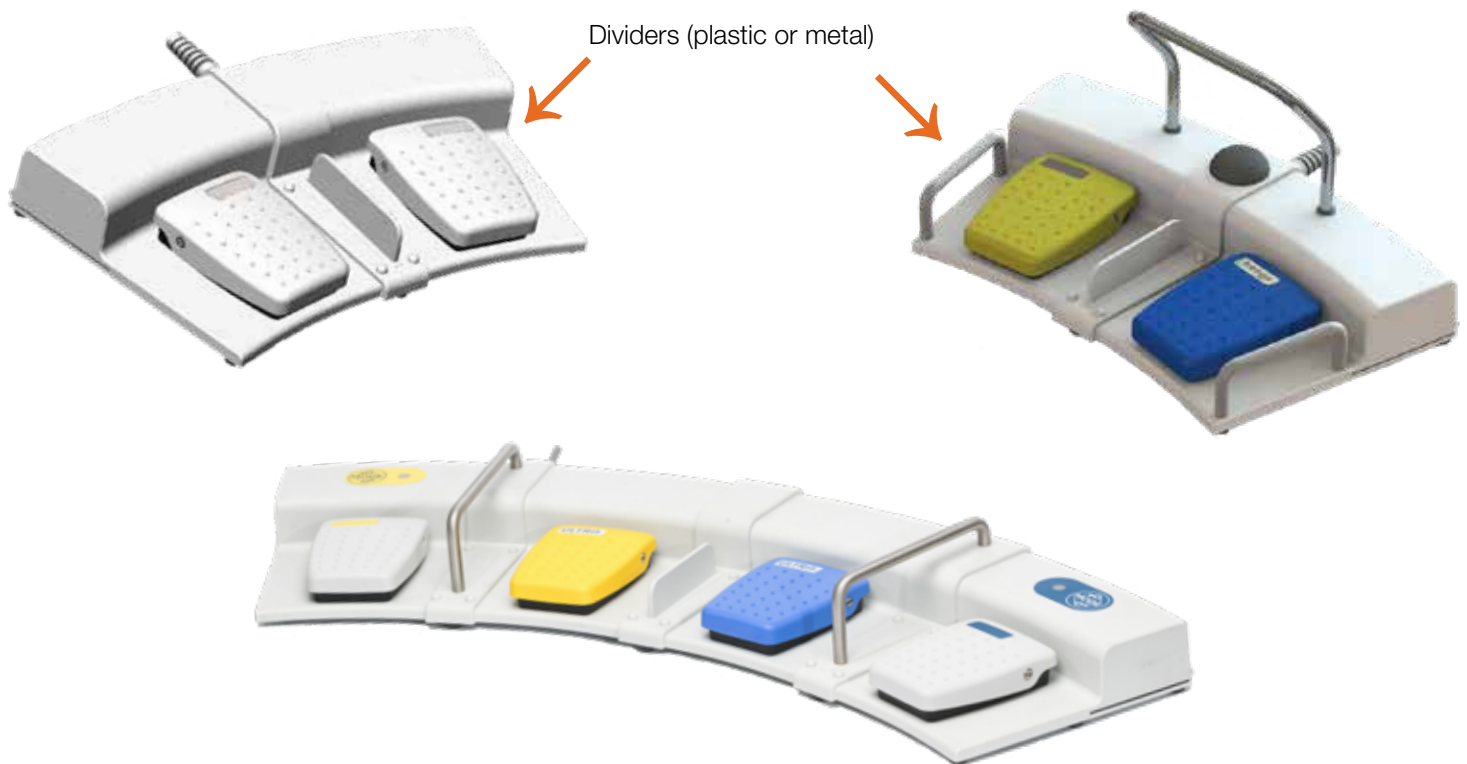

Design concept of the product

Example shown: Single pedal and double pedal base can be linked to make 3 or 4 pedal bases



Pedals in different colours with or without customer specified labels

Complementing the Medical Footswitch Design Platform, Herga's IEC 60601/UL 60601 medically approved range of footswitches include the well proven 6226 series that can be selected with environmental protection options EN60529 IPX7 or IPX8 on request. Several footswitches in this series with their bases can be connected modularly next to each other. Thanks to this modular structure, many different switching tasks can be implemented. Special features include USB or bluetooth, customized cables and a big variety of different colour options for the pedals.



Switching action per footswitch

- Single Pole Normally Open (SC)
- Single Pole Change Over (CC)
- Double Pole Normally Open (DO)
- Double Pole Normally Open Two Stage (DA)
- Combination of Switching Options

Electrical rating for the footswitches

- 0.1A 24 V AC/DC
- 3A 24 V AC/DC max.

Reference dimensions in mm

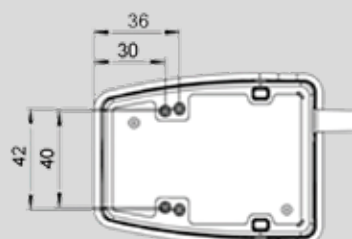
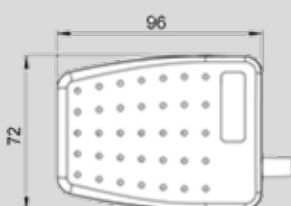

M3 Brass fixing inserts
Bottom holes as standard

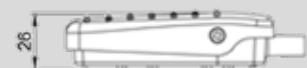

Bases with switches (Puck - Haptic - Tactile)

Add up to two switches per pedal + base

The unique feature of the **Medical Footswitch Design Platform** is the ability to combine up to five bases (with a footswitch) and each base with or without switches. These switches can be puckswitches, haptic switches or domed tactile switches. Additionally, each footswitch can have different switching actions and each switch different electrical ratings.

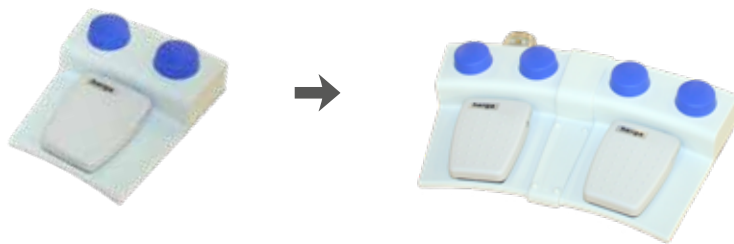
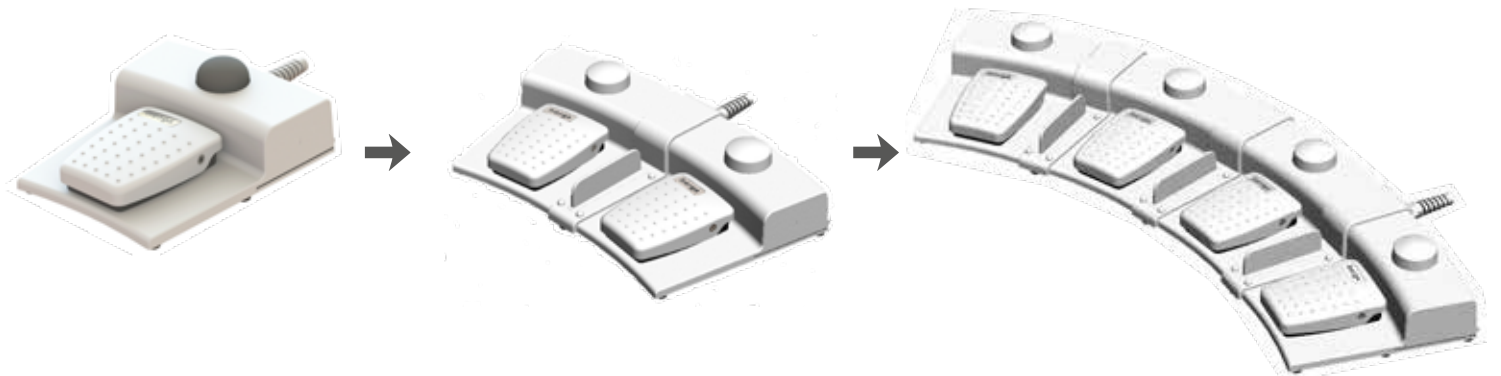

6241 puckswitch



6244 haptic switch



6245 tactile button

The 6241 Puckswitch

There are different colour options and functions for the switches & buttons. The 6241 puckswitch is available in the colours black, grey, blue and yellow. They are also available with Operating Force > 10N on request.



- Lightweight operation over the entire top surface
- Designed to withstand heavy loads
- Customer colours and logos available on request

Reference Dimensions

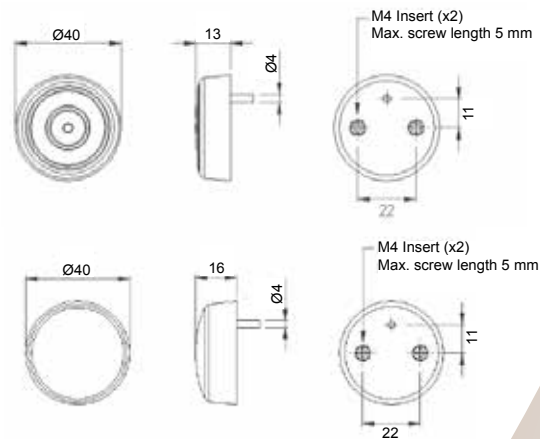

General Specifications

Degree of protection EN 60529 IP67
(IP68 upon request)

Electrical rating max. 50 mA 24 V DC

Contact configuration SPST N/O

Operating Force up to 10N standard or
>10N (nom. 15N) on request

Operating and storage temperature + 10°C to + 50°C

Body material Thermoplastic

Weight 0.06 kg

Switch specifications

The 6244 Haptic switch

There are different colour options and functions for the switches & buttons. The 6244 haptic switch is available in the colours black, grey, blue and yellow.



- High mechanical stability
- Easy to clean
- Haptic feedback in the form of an audible “click” when pressed
- Rated IP67

Reference Dimensions

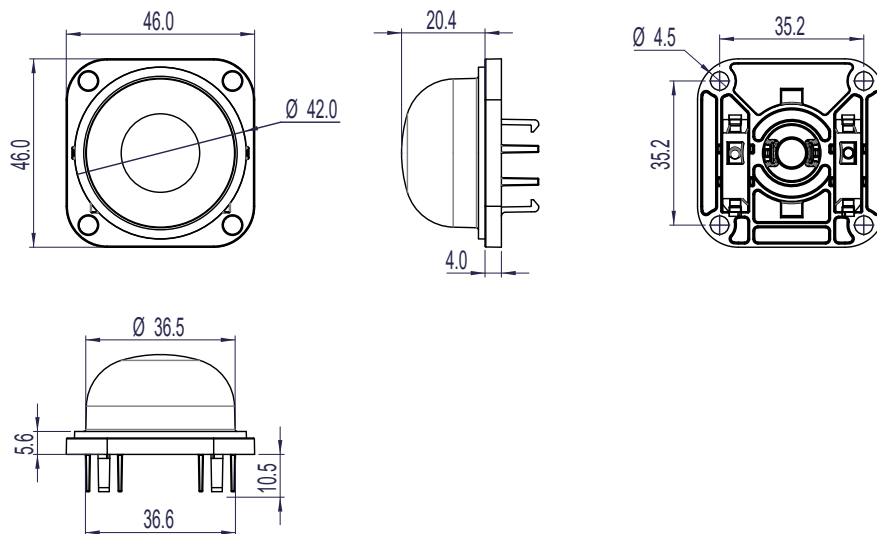

General Specifications

Degree of protection	IP67	Storage temperature range	-20° C to +50° C
Micro switch Electrical Rating	0.1A 125/250V AC, 0.1A 30V DC or 3A 24V AC	Body material	Acetal Copolymer
Contact Configuration	SPDT/ DPDT Momentary	Bellows material	PVC Bellows
Electrical Rating	0.1A 24 V DC 3A 24 V AC/DC max.	Weight	25g
Operating temperature range	+10° C to 50° C	Average mechanical life	1 x 10 ⁶ (dependent on application)

The 6245 Tactile button

There are different colour options and functions for the switches & buttons. The 6245 domed tactile button is available in the colours black, grey, blue and yellow.



- Attractive raised dome style button
- Momentary action
- IP68 rated

Reference Dimensions

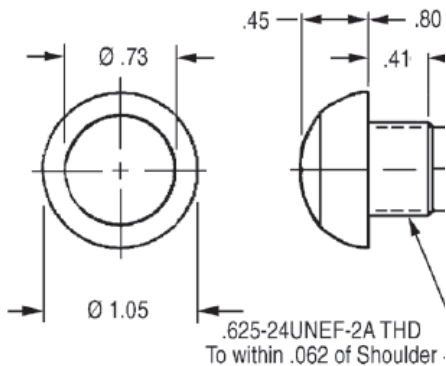

Electrical Ratings

Load	Sea Level @ 28VDC or 115VAC, 60/400 Hz	Cycles
Resistive	10 A	100,000
Resistive	15 A	25,000
Inductive	5 A	100,000
Lamp	3 A	100,000
Center Contact	3 A max	100,000

General Specifications

Mechanical

Mechanical Life	1,000,000 cycles, circuit forms 1,2 & 6 100,000 cycles, circuit forms 3,4 & 5
Seal	IP68
Operating Temp Range	-55° C to +85° C
Operating Force	2.0 lbs. to 4.0 lbs., +0,5/-1.0 lb.
Total travel	0.075 +/- 0.015 inches
Overtravel	0.012 inches min
Movement Differential	0.015 inches min

Materials

Case	Anodized aluminum alloy
Button	Thermoplastic
Terminals	Brass with silver plate, gold plate for logic level
Terminal Hardware	Screws, lockwasher and terminal lugs
Mounting Hardware	Hex nut, lockwasher and panel seal when applicable

Special Features and cables

Special features include USB and Bluetooth

All of the electrical switching functions for the Medical Footswitch Design Platform are typically output via a single cable for straightforward machine connection, with flying leads and stripped cable cores or with a preferred connector as required, or alternatively via our closed network Bluetooth connection or via USB 2.0.



USB 2.0 features include:

- Emulates keyboard or mouse function (using same pcb)
- Plug and play technology, no additional drivers required
- Works with Windows, Linux / Mac operating systems
- Emulation of up to 3 simultaneous keystrokes per pedal
- Electrical rating: 20mA 5V DC

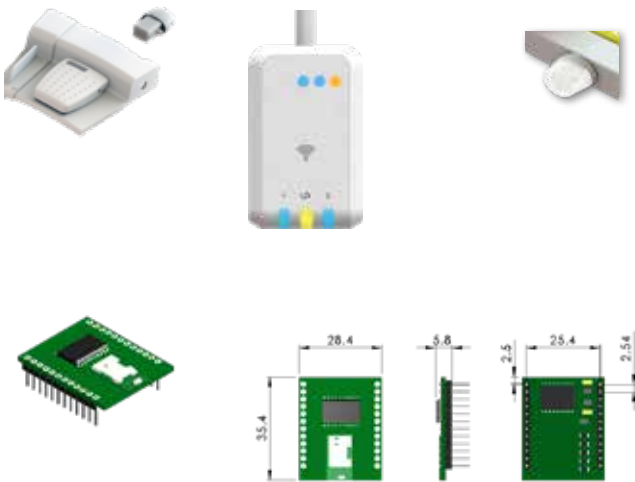

Bluetooth features include:

- Secure PAN (Personal Area Network) with up to 2 transmitters
- Ultra low power with 1µA sleep current
- Range: Nominally 10m (up to 15m line of sight, latency may increase with range)
- Selectable latency:
 - Setting 1: Typically <200 ms at 10m
 - Setting 2: Typically <100 ms at 10m
- Auto wake from sleep/re-connect on press of the pedal

Ref. dimensions Bluetooth receiver in mm

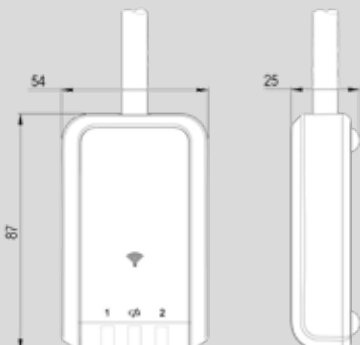

General Specifications

Supply rating	12-24V DC
Output configuration	Switch output: Normally open contact relay (1.75A 24V DC MAX)
Degree of protection	EN 60529 IP44
Storage temperature	-20 to +65° C
Operating temperature	0 to +40° C
Body material	Thermoplastic
Standards/approvals	Low Voltage Directive 2014/35/EU, REACH, RoHS & WEEE

Design concepts and configurations for common medical use

For the most common applications in the medical industry, we have created full design concepts and configurations.

These can be ordered fully fitted under the product name MD2G-BAA-BA1-EZZ-000 and MD2G-CGA-BA0-ZZC-001.

Any of the footswitch options (single or multipedal) can be ordered with different cables: Grey without screen, Grey with screen or customer selected cable (must comply with UL Style AWM 2464) or no cable for use with bluetooth.

MD2G-BAA-BA1-EZZ-000 - Dual-pedal footswitch & haptic puckswitch

Special dual-pedal version of 6226 series footswitch with 6244 haptic puckswitch

- Fitted with 2x 6226-AABB-ZZZA-001 footswitch
- Fitted with 1x 6244 haptic puckswitch in centre
- Complete with 2m of cable and Heyco gland
- Rated IPX7
- Footswitch electrical rating: 3A 24V AC/DC
- Haptic puckswitch electrical rating: 3A 24V AC/DC
- Wired normally open



MD2G-CGA-BA0-ZZC-001 Electrosurgical Footswitch

- 2 pedal medical grade footswitch for electro surgical applications
- Left pedal Yellow labelled 'CUT', normally open contacts
- Right pedal Blue labelled 'COAG', normally open contacts
- Complete with 2 meters of grey 3 core cable with free wire ends, exit on the left side
- Steel divider bar in centre and steel handle to rear
- Sealed to IPX7
- Rated 3A 24V AC/DC



Reference dimensions in mm

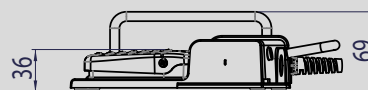
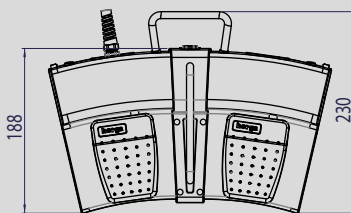

Specifications and Dimensions

The Medical Footswitch Design Platform in many variations

Herga has developed a comprehensive range of standard variants that can be used in the new medical modular base system. This range covers straightforward selection in combinations that span a single footswitch to a multiple switch combination including 5x footswitch plus up to 2 x 3 switch configurations per footswitch. The entire range is fully medically approved on-delivery.

The modular base system is also suitable for industrial and commercial use.

	Fitted with				
	6226 Footswitch	6241 Puckswitch	6244 Haptic Switch	6245 Tactile Switch	USB
Max electr. rating (gold contacts)	0.1A 24V AC/DC	-	0.1A 24V AC/DC	-	20mA 5V DC
Max electr. rating (silver contacts)	3A 24V AC/DC	50mA 24V DC	3A 24V AC/DC	3A 24V AC/DC	-
Storage Temp	-20° to 70° C	10° to 50° C	10° to 50° C	-20° to 70° C	-20° to 70° C
Working Temp	-20° to 60° C	10° to 50° C	10° to 50° C	-20° to 60° C	-20° to 60° C
Air Pressure: Operating Altitude	Up to 5000m/54kPa	Up to 5000m/54kPa	Up to 5000m/54kPa	Up to 5000m/54kPa	Up to 5000m/54kPa
Air Pressure: Storage / Transport Altitude	Up to 12000m/20kPa	Up to 12000m/20kPa	Up to 12000m/20kPa	Up to 12000m/20kPa	Up to 12000m/20kPa
Storage & Working Humidity	30 to 75%	30 to 75%	30 to 75%	30 to 75%	30 to 75%

Disclaimer

- The rating of the Bluetooth will be the same as the rating of the switching component. If a multi-pedal has a number of different switches attached (each at a different rating) then the product will be rated as the lowest value.
- The exact specification will be determined after the combination of the individual products.
Please contact a Herga Sales Specialist with your specific needs.

Specifications and Dimensions of 1 to 4 pedal and base

Please see below the dimensions in mm.

1-Pedal

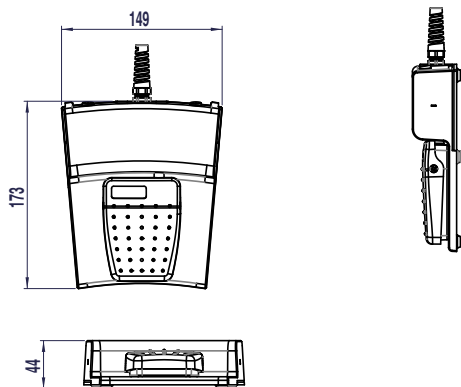

1-Pedal + Puck

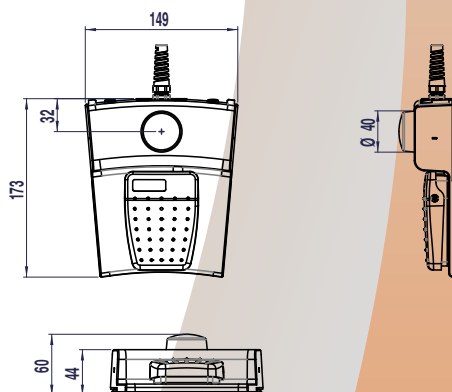

2-Pedal

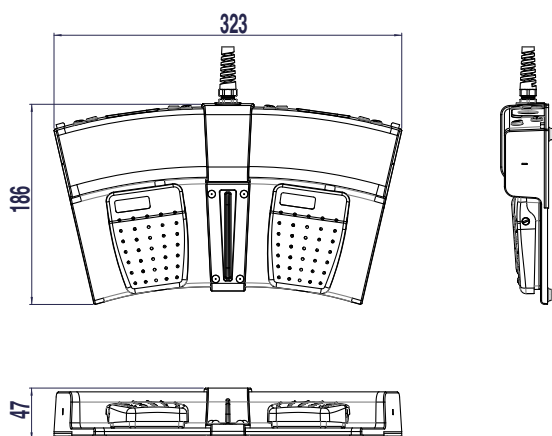

2-Pedal + Puck

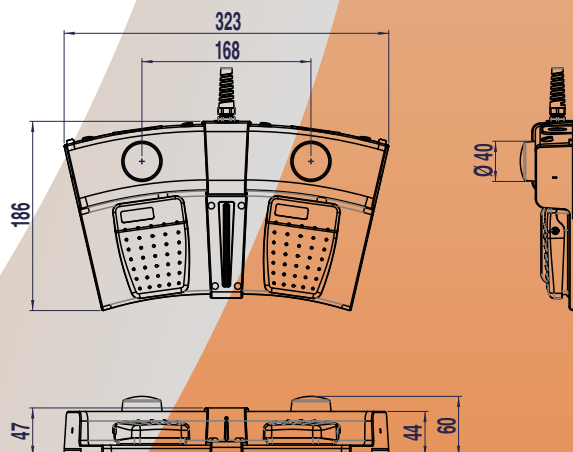

Specifications and Dimensions

Specifications and Dimensions of 1 to 4 pedal and base

Please see below the dimensions in mm.

3-Pedal

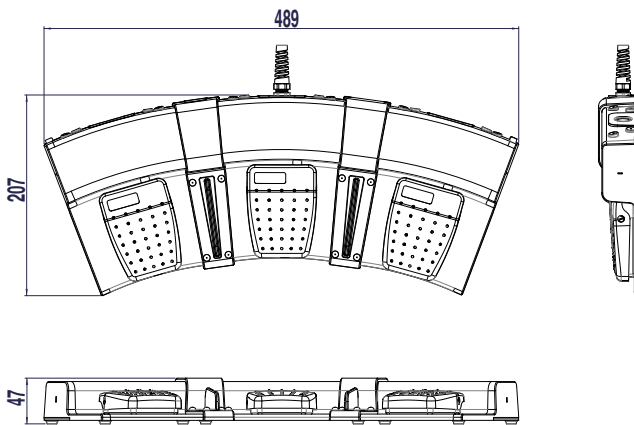

3-Pedal + Puck

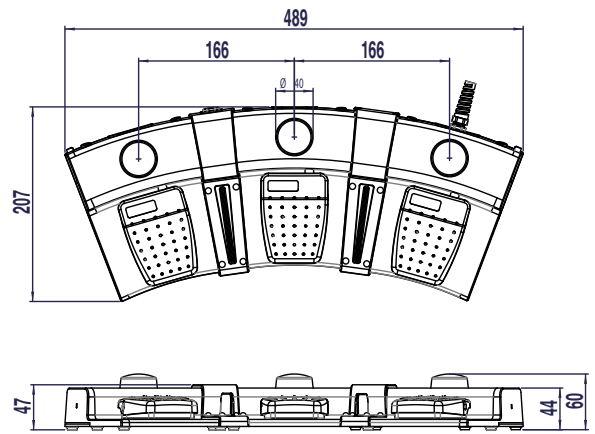

4-Pedal

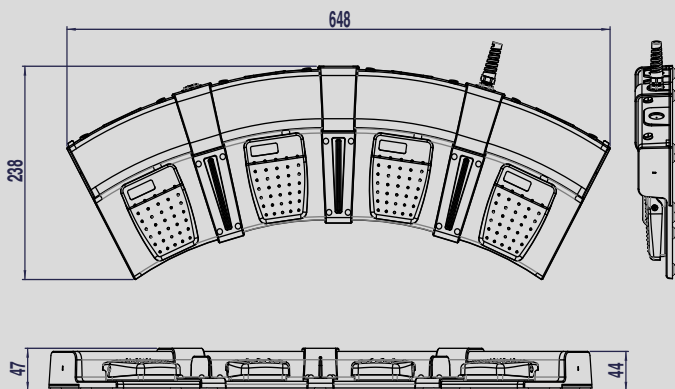

4-Pedal + Puck

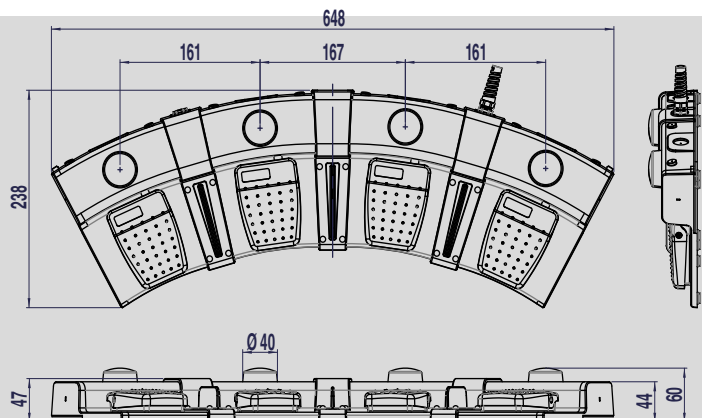

As with many of our products, Herga also provides a selection of accessories for the Medical Footswitch Design Platform. Whether it is for customer convenience, easier handling or a safer work environment, a wide range of modular accessories may be included such as tubular steel carrying handles, open guards or roll bars. For improved operational safety, each footswitch may also be separated with a raised divider built into the joining spacer. Steel base plates are available for added weight and stability.

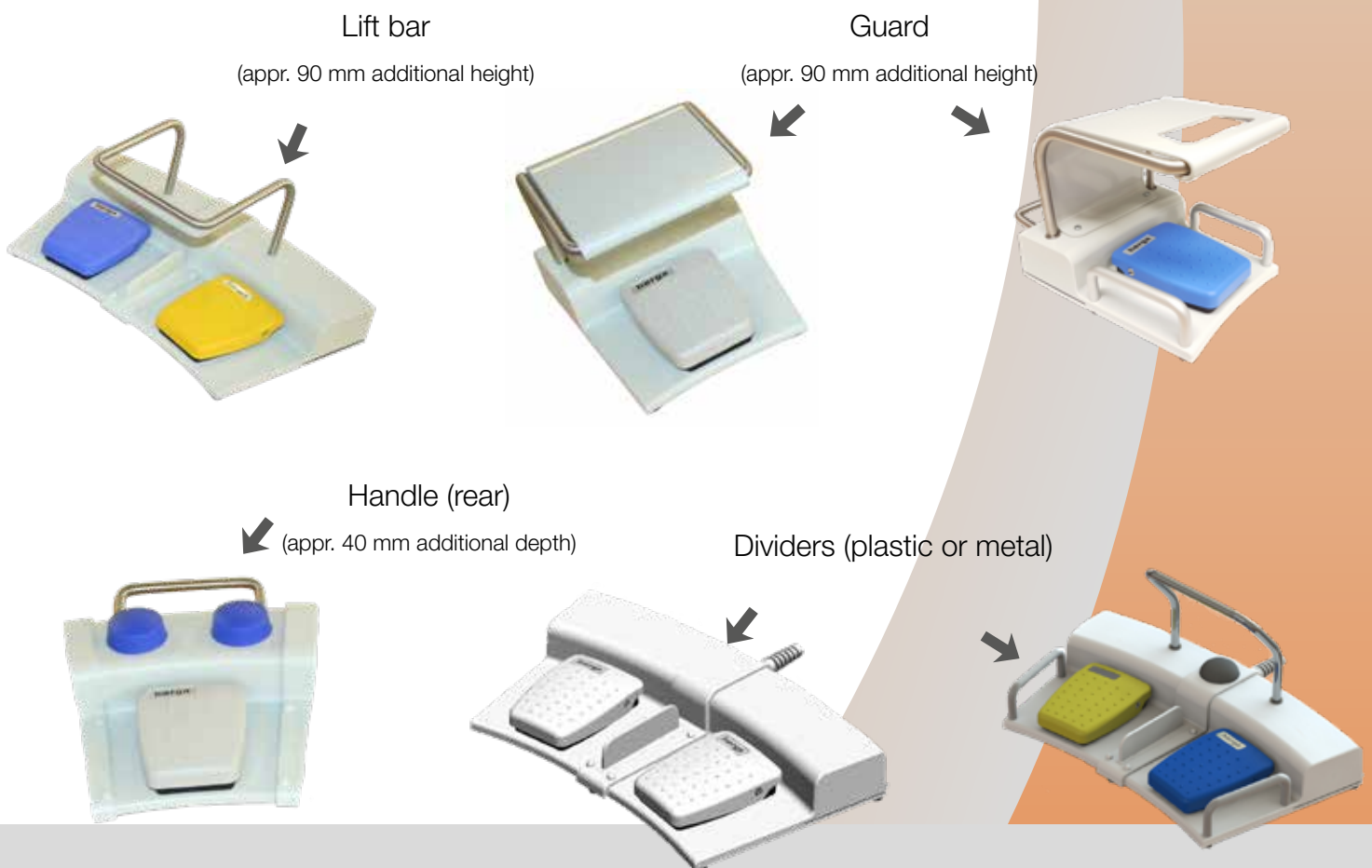

Ordering information

Please contact Herga for availability of the individual products

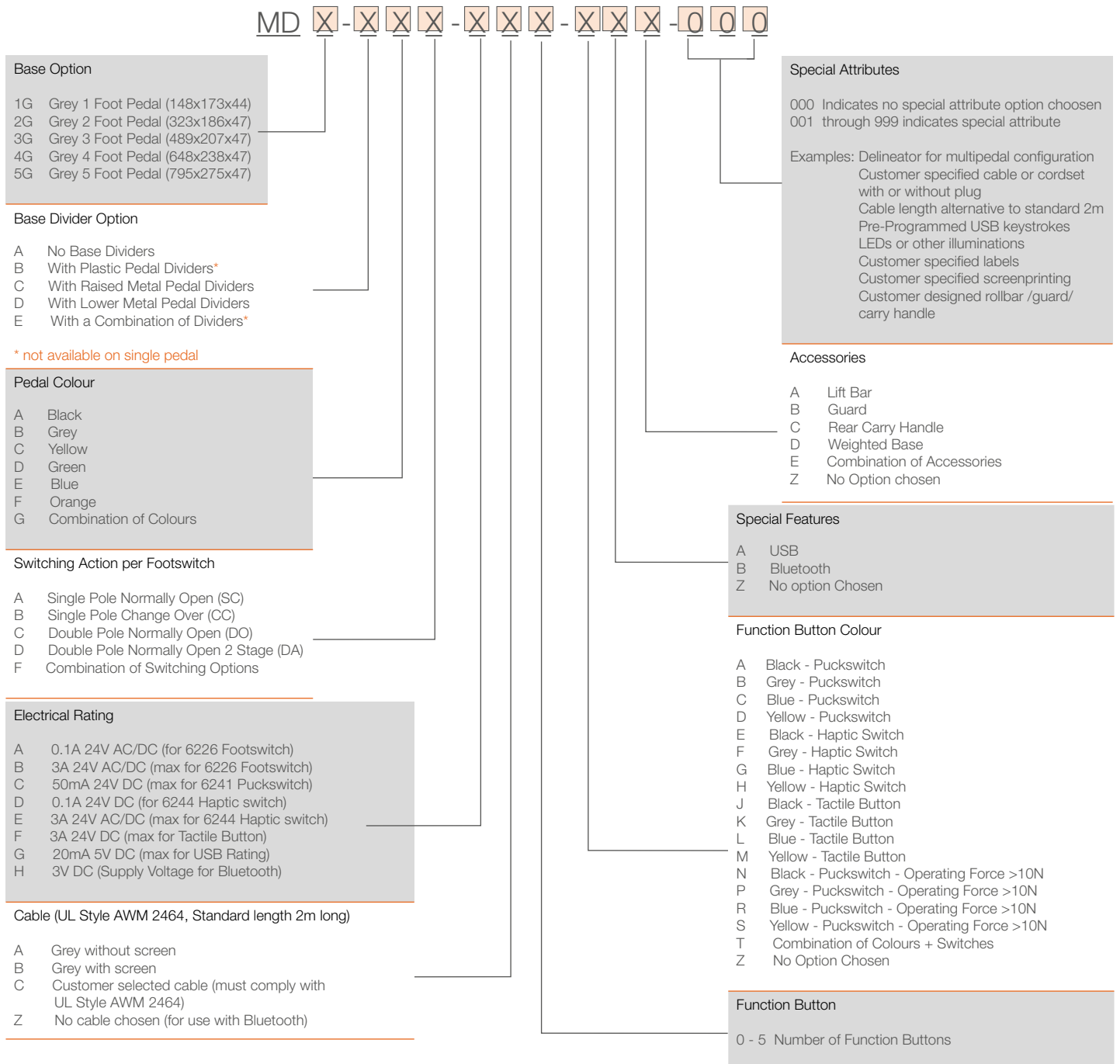

The Herga company philosophy stands for flexible production processes that takes into account customer specific requirements whilst facilitating small serial production at the same time.

Certificate Of Compliance

Certificate Number 2020-07-29 (Org.), 2020-08-31 (C1)-E353500

Report Reference E353500-D1004-1/A0/C1-UL

Issue Date 2020-07-29 (Org.), 2020-08-31 (C1)

Issued to: Herga Technology Ltd

Applicant Company: Northern Way
Bury St Edmunds, IP32 6NN United Kingdom

Listed Company: Same as Applicant

**This is to certify that
representative samples of**

Medical Electrical Foot-Switches

MD; followed by 1G, 2G, 3G, 4G, 5G, 1W, 2W, 3W, 4W, 5W, 1B, 2B, 3B, 4B, 5B; followed by A, B, C, D, E; followed by A, B, C, D, E, F, G; followed by A, B, C, D, F; followed by A, B, C, D, E, F, G, H; followed by A, B, C, Z; followed by 0, 1, 2, 3, 4, 5; followed by A, B, C, D, E, F, G, H, J, K, L, M, N, P, R, S, T, Z; followed by A, B, Z; followed by A, B, C, D, E, Z; followed by 000-999;

Have been investigated by UL in accordance with the Standard(s) indicated on this Certificate.

Standard(s) for Safety: ANSI/AAMI ES60601-1: A1:2012, C1:2009/(R)2012 and A2:2010/(R)2012, CSA CAN/CSA-C22.2 NO. 60601-1:14

Additional Standards: IEC 60601-1 Edition 3.1 (2012) / EN 60601-1:2006 + A1:2013 + A12:2014

Additional Information: See the UL Online Certifications Directory at www.ul.com/database for additional information.

Only those products bearing the UL Certification Mark should be considered as being covered by UL's Certification and Follow-Up Service.

Recognized components are incomplete in certain constructional features or restricted in performance capabilities and are intended for use as components of complete equipment submitted for investigation rather than for direct separate installation in the field. The final acceptance of the component is dependent upon its installation and use in complete equipment submitted to UL LLC.

Look for the UL Certification Mark on the product.

This is to certify that representative samples of the product as specified on this certificate were tested according to the current UL requirements.

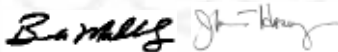

Bruce Mahrenholz, Assistant Chief Engineer, Global Inspection and Field Services, UL LLC
Joseph Hosey, General Manager, Director of Sales – Canada, UNDERWRITERS LABORATORIES OF CANADA INC.

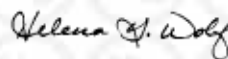

Helena Y. Wolf, Director, Global Market Access Operations, UL LLC

Any information and documentation involving UL Mark services are provided on behalf of UL LLC (UL) or any authorized licensee of UL. For questions, please contact a local UL Customer Service Representative www.ul.com/contactus



Important Safety Instructions

This leaflet contains important information for the safe installation and maintenance of the product. It must be read carefully before commencing installation.

The MD series footswitch is an accessory for use with electrical equipment and is approved to General Medical Electrical Equipment Standards:

- EN 60601-1:2006+A12:2014
- IEC 60601-1:2005+A1:2012
- CAN/CSA C22.2 No 60601-1-14ANSI/AAMI ES60601-1:2005

Switch Specification:

Standard Model (without cable)	Size (mm)	Weight (g)
1-Pedal	150 x 174 x 44	350
2-Pedal	322 x 188 x 48	720
3-Pedal	490 x 207 x 48	1150
4-Pedal	648 x 240 x 48	1450
5-Pedal	793 x 275 x 48	1950

Enclosure rating: Class 2 - Double Insulated.

(No single fault will result in dangerous voltage)

Electrical: Safety Extra Low Voltage (SELV)

50mA, 0.1A, 1.75A or 3A 24V AC/DC)

Any secondary circuit must be supplied by a limited power source according to EN60950-1.

Waterproof rating options:

A. Ingress protection IPX7 (Immersion up to 1m for 30 minutes shall not result in harmful water ingress)

B. Ingress protection IPX8 - Upon request (Immersion at 1,5m for 45 minutes shall not result in harmful water ingress)

Instructions for Use (In Medical Environment)

Operation of the device should be by a trained medical professional. The device has no applied parts and should not be accessible to patients.

Installation of Product

Installation and maintenance work must be carried out by competent persons. The instructions and relevant medical standards, federal, state, local health and safety regulations and codes must be followed. Before connecting the product cable, ensure the connections to the cable are isolated from the supply. Check circuit diagram before product installation. If the footswitch cord is to be fitted with a plug, check the Electrical Equipment Standard for prohibited plug combinations before fitting. Connect the cable and check the product functions, as designed. Complete the installation and finally tighten all cable strain relief fittings.

Additional WARNING for Medical Applications

Medical environments have high demands for safety and hygiene. The use of inadequate products can cause serious injuries to the user and patient.

This footswitch should not be used as an emergency stop device.

This footswitch is not suitable for applications in the presence of a flammable anaesthetic mixture with air or with oxygen or nitrous oxide.

Footswitches fitted with guards and rollbars are to protect against accidental operation. Please do not stand on protection devices.

Maintenance (in line with the European POWER regulations or local code requirements)

Inspect visually and functionally at a minimum of regular weekly intervals to ensure:

- The device switches on when pressed and switches off without delay when released.
- The cable is free from cuts and abrasions; light scuffing is acceptable.
- The enclosure has not suffered excessive damage that would present a hazard or prevent switch operation.
- If a plug is fitted, check for damage. Is the casing cracked or the pins bent?

Check the outer covering (sheath) of the cable is being gripped where it enters the equipment or plug fitted. Look to see if the coloured insulation of the internal wires is showing.

Note: Any unapproved modifications may render the product unsafe and will invalidate all warranties and approvals.

Cleaning Product

This device is not supplied sterile, or intended to be sterilized. Clean regularly and thoroughly to avoid the build-up of hazardous bacteria and dirt. The device should be wiped clean to remove soils, e.g. dust, dirt and organic matter using a cloth or soft fabric with a general-purpose detergent.

The product can be disinfected using isopropyl alcohol wipes (70%) or immersion in a disinfectant solution (follow manufacturer disinfectant directions) for a maximum of 15 minutes at a depth no greater than 1 meter.

Note: Chlorine based disinfectants may lead to deterioration of this device.

After contact, rinse thoroughly under running water and allow water to drain by holding the footswitch by the cable and allowing liquid to drain away, shake well and wipe residual moisture from the enclosure. Carefully hard-dry using non-shredding absorbent cloth, industrial hot air dryer or place into a drying cabinet.

Instructions for Disposal

This device is not for recycling and should be disposed of in accordance with local bylaws.

Herga Technology Ltd. was founded in 1947 with its headquarters in Bury St. Edmunds, UK.

We are a leading UK manufacturer, designer and exporter of footswitches, hand controls and sensing solutions. We are specialising in the medical industry and industrial branches like metal processing and heavy industry.

Our customers appreciate and trust our products, ideas and services. We always strive to meet our customer's needs with a strong commitment to innovation, quality and service. These are the cornerstones of our philosophy.

Approvals

Many of our products hold international approvals including IEC / UL 60601 and our UK manufacturing facility is regularly audited by UL and CSA. We are certified to ISO9001:2015 and ISO 13485:2016 (medical approval).

From concept to production

Herga utilises its core competences and wide experience in medical and other specialised markets to design high quality customer products. With our attention to Lean Manufacturing we are able to offer the competitive pricing the market demands.

Our design capabilities include:

- 3D Solid modelling
- Injection mould tool design & production
- Rapid prototyping
- Printed circuit board design
- Injection moulding
- Electro-mechanical products
- Manufacturing facilities
- Cell-based batch assembly
- Microcontroller based systems
- Custom cables



Variohm Holdings

In 2013, Herga became part of Variohm Holdings Ltd. Variohm Holdings Ltd. is a group of engineering companies specialising in Sensors, Switches, Motion Control and Systems. The individual companies within the group act with great autonomy but have access to shared expertise and resources. Variohm Holdings Ltd. is part of the discoverIE group.

For more information, please contact our technical sales team:

ALCYON
ÉLECTRONIQUE
Tel : +33 (0) 1 34 94 77 00
<https://alcyonelectronique.fr/>
commercial@alcyonelectronique.fr