

MODEL 7710
CRYOGENIC TEMPERATURE TRANSDUCER

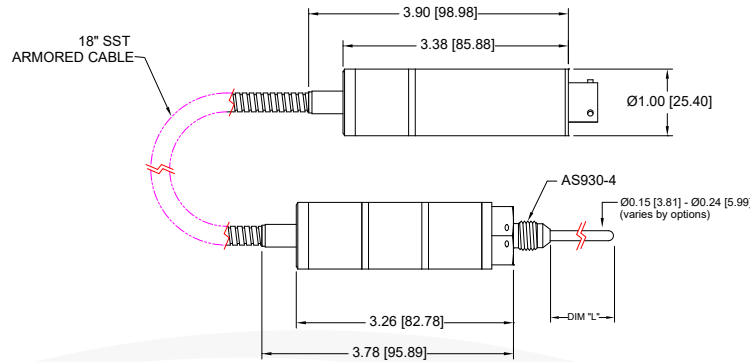

STANDARD WIRING

PIN	VDC	4-20mA
A/1	+EXC	+EXC/SIG
B/2	+SIG	N/C
C/3	-SIG	N/C
D/4	-EXC	-EXC/SIG
E/5	N/C	N/C
F/6	N/C	N/C

L = 0.50 TO 7.00 INCH PROBE LENGTH

**Standard configurations shown.
Please consult factory for other options.**

PRODUCT OVERVIEW:

The Model 7710 from GP:50 is a cryogenic temperature transducer, designed to provide high-reliability low-temperature measurements to -320°F (-196 °C) within a rugged, all-stainless steel package. Remotely mounted electronics provide a high-level signal output of either 4-20 mA; 0 to 5 Vdc; or 0 to 10 Vdc, as well as choice of RS232, RS485 or CAN protocol, for improved cryogenic measurement accuracy and higher resolution. Stainless steel armor jacketed cabling provides added protection from extreme environmental conditions.

FEATURES:

- Cryogenic service down to -320 °F (-196 °C)
- Accuracy of ±1% FSO
- Lightweight, < 10 oz. (0.2 kg)
- Hydrogen and LOX compatibility options available
- Remote electronics provide high-level output
- Rugged all-stainless steel design

APPLICATIONS:

- Aerospace ground support
- Rocket propulsion systems
- Military and defense
- Fuel test stands
- Cryogenic custody transfer

OPTIONS:

- Custom temperature probe lengths
- 0 to 5 Vdc, 0 to 10 Vdc or 4-20 mA output
- RS232, RS485 or CAN protocol
- Alternate remote cable lengths
- Hastelloy, Monel or Inconel wetted parts
- Various MIL-SPECS available. Consult factory.

GP:50 MODEL 7710

REFERENCE SPECIFICATIONS

(Standard configurations shown, consult factory for other options)

ELECTRICAL	
Output Signal:	0 to 5 Vdc, or 0 to 10 Vdc (isolated or non-isolated) or 4-20 mA
Temperature Output:	100 Ω 2-wire platinum RTD standard 1,000 Ω 2-wire platinum RTD optional
Excitation Voltage:	9 to 32 Vdc 14-32 Vdc for 0-10V, and isolated output
Circuit Protection:	EMI/RFI; some options will affect EMI/RFI rating
Response Time:	<2 sec

MATERIALS OF CONSTRUCTION	
Wetted Parts:	17-4 Stainless Steel (Optional Inconel, Nitronic 50 or Monel)
Housing:	316 Stainless Steel Tubing: 1/8" Flexible metal hose
Armored Cable:	Braided 316L

ACCURACY (RSS): Hysteresis, Non-Linearity & Repeatability @ +70 °F)	
Static Accuracy:	$\pm 3.0\%$ FSO, $\pm 1.0\%$ FSO optional
Zero/Span Balance:	$\pm 1.0\%$ FSO

Calibration:	NIST Traceable Cert
Workmanship:	IPC-A-610 Soldering
Quality System:	ISO 9001

Options may affect specifications.
Please consult factory for your specific needs.

MECHANICAL	
Process Connection:	AS930-4 pressure port
Electrical Connection:	MIL PTIH-10-6P standard, options available
Probe Length:	1.55" (custom lengths available)
Approximate Weight:	<1 lb (0.5 kg)

SYSTEM PRESSURE	
Designed for up to 2000 PSI (138 BAR) higher system pressures also available	

THERMAL SPECIFICATIONS	
Operating Range:	-350 °F to +150 °F (-212 °C to +65 °C)
Calibrated Range:	-320°F to +70 °F (-195.6 °C to +21 °C)

ALCYON

ÉLECTRONIQUE

Tel : +33 (0) 1 34 94 77 00

<https://alcyonelectronique.fr/>

commercial@alcyonelectronique.fr

