

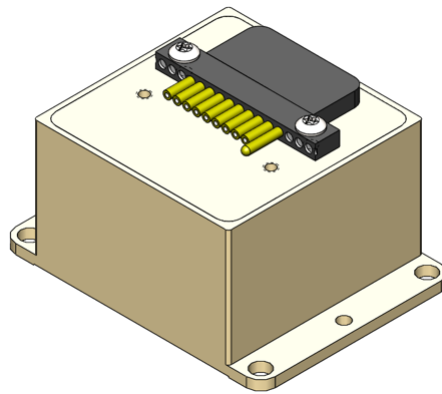

LMRK007XIMU-2000-200-330

Technical Summary



Web: <https://www.gladiatortechnologies.com>
Email: support@gladiatortechnologies.com
Telephone: 425.363.4180

ALCYON
ÉLECTRONIQUE
Tel : +33 (0) 1 34 94 77 00
<https://alcyonelectronique.fr/>
commercial@alcyonelectronique.fr

Contents

1	Sensor Performance	4
1.1	Gyroscopes	4
1.2	Accelerometers	4
1.3	Environmental	5
2	Mechanical	6
2.1	General Specifications	6
2.2	Part Label	6
2.3	ESD Protection	7
2.4	Outline Drawings	8
3	Communication Interface	9
3.1	General	9
3.2	RS-422/485	9
3.3	External Sync	10
3.4	Self-Test	10
4	Firmware	11
5	Timing	11
5.1	Message Transmission Delay	12
5.2	Baud Rate Resolution	12
6	Message Protocol	13
7	Power	13
8	Pin Configuration	14
8.1	Single Input Ext. Sync (-300 Configuration)	14
9	Axis Definitions	15
10	Interfacing with the IMU	15
A	Simplified Equivalent Input Diagrams	16
A.1	RS-485	16
B	Message Details	17
B.1	LMRK007X IMU	17
B.2	RS-485 Synchronized with External Sync	17
C	Contact Information	18

Overview

The LandMark[®]007X IMU is a six axis MEMS IMU with low noise gyroscope and accelerometer sensors. Each IMU is factory calibrated over temperature and conditioned to repeatably perform over demanding environments.

The IMU is enabled with VELOX[®] high speed processing, a Gladiator Technologies proprietary technology for rapid sampling. VELOX[®] technology is the driver for increased data outputs, increased filtering options and extremely low latency.

VELOX[®] is also available with enhanced options in the VELOX[®] Plus package. These upgraded features include higher bandwidth, message rates, and Baud rates from the standard product offering. In addition, custom data rates are available. These specifications are identified further in [Section 5](#).

1 Sensor Performance¹

1.1 Gyroscopes

Specification	Value	Unit	Variance
Sensor Range	± 2000	$^{\circ}/s$	N/A
ARW	0.002	$^{\circ}/s/\sqrt{Hz}$	1σ
	0.09	$^{\circ}/\sqrt{hr}$	
Bias Stability	4	$^{\circ}/hr$	
Bias Over Temperature	0.075	$^{\circ}/s$	
Scale Factor Error	0.05	%	
Alignment	0.5	mrad	
G-Sensitivity ²	0.001	$^{\circ}/s/g$	
Vibration Rectification Error	1	$^{\circ}/hr/g_{rms}^2$	
Maximum Bandwidth ^{3,4}	Standard: 350	Hz	N/A
	VELOX [®] Plus: 600		

1.2 Accelerometers

Specification	Value	Unit	Variance
Sensor Range	± 200	g	N/A
VRW	5	mg/\sqrt{Hz}	1σ
	2.1	$m/s/\sqrt{hr}$	
Bias Stability	5	mg	
Bias Over Temperature	60	mg	
Scale Factor Error	0.6	%	
Alignment	5	mrad	
g^2	1	mg/g^2	
Vibration Rectification Error	1	mg/g_{rms}^2	
Maximum Bandwidth ⁴	Standard: 350	Hz	N/A
	VELOX [®] Plus: 600		

¹Specification values assume a nominal 25°C unless otherwise stated.

²When acceleration < 16g. If acceleration exceeds this value g-sensitivity increases to 0.03 $^{\circ}/s/g$.

³Gyroscope bandwidth is independent of accelerometer bandwidth.

⁴User selectable from 200 to 600 Hz in 50 Hz increments.

1.3 Environmental

Specification	Value
Shock	1000 g 1/2 ms powered
Vibration	15 g_{rms} (50 Hz to 2 kHz)
Operating Temperature ⁵	-50°C to +85°
Calibrated Temperature	-50°C to +85°
Non-Operating Temperature ⁶	-55°C to +85°
MTBF ⁷	110,739 hrs

⁵IMU is rated electronically for this temperature range.

⁶IMU is related mechanically for this temperature range.

⁷Per MIL-STD-217F, Notice 2 and ANSI/VITA 51.1-2008 with environment: ACI at 55°C ambient.

2 Mechanical

2.1 General Specifications

Specification	Value	Tolerance	Unit
Mass	25	± 1	grams
Imperial Dimensions (W x L x H) ⁸	1.00 x 1.00 x 0.65	± 0.01	in
Metric Dimensions (W x L x H) ⁸	2.54 x 2.54 x 1.65	± 0.03	cm
Mounting	4ea. No.2-56 Screws	N/A	-

2.2 Part Label



Figure 1: LMRK007X IMU part label with axis definitions, serial number, and date code of manufacturing.

⁸The mounting flange adds an additional 0.33 in (0.084 cm) of total width to the package. Flange height is 0.05 in (0.013 cm) and runs the entire length of the package.

2.3 ESD Protection

Pin No.	Assignment	ESD Limit	Current Limit
1	RS-422/485 A (+)	± 15 kV HBM ⁹	-
2	RS-422/485 B (-)	± 15 kV HBM	-
3	Power Ground	-	-
4	Not Connected	-	-
5	Supply Voltage ($V_{I,N}$)	< +20 V	< 100 mA
6	External Sync Input	± 2 kV HBM	< 25 mA
7	Signal Ground	-	-
8	Self-Test (3.3 V Logic)	± 2 kV HBM	< 25 mA
9	Case	-	-

⁹Human body model.

2.4 Outline Drawings

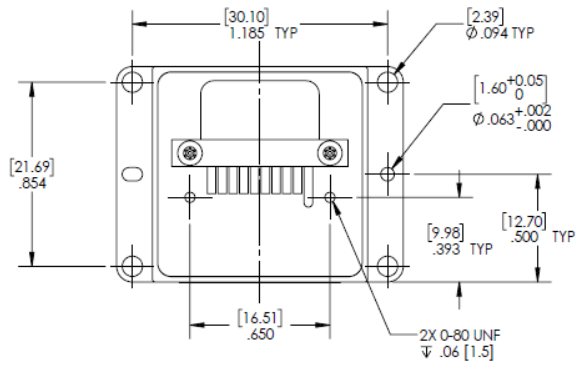

(a) Top View

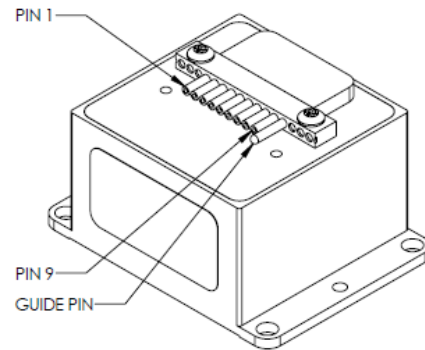

(b) Isometric View

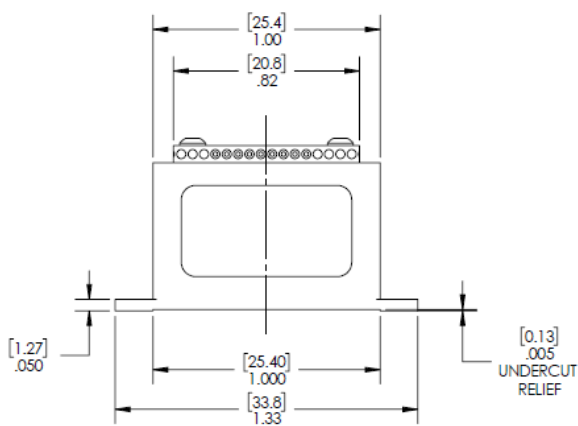

(c) Front View

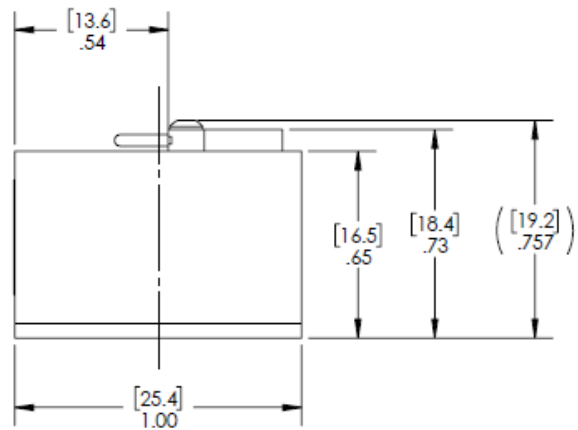

(d) Side View

Figure 2: Views of the LMRK007X.

3 Communication Interface

3.1 General

Specification	Standard	Plus	Unit
Interface ¹⁰	RS-422/485		-
Data Format	16, 24, or 32		bit
Max. Transmission Rate ^{11,12}	3	7.5	MBaud
Max. Output Data Rate (ODR) ¹²	8	10	kHz

3.2 RS-422/485¹³

Specification	Value	Unit
Common-mode voltage	$-7 \leq V_{CM} \leq +12$	V
Driver differential output level ¹⁴	$2 \leq V_{OD} \leq V_{IN}$	V
Driver output short-circuit current	$-250 \leq I_{SC} \leq 300$	mA
Driver Input Impedance ¹⁵	≥ 61	k Ω
Differential termination impedance	120	Ω
Receiver differential threshold voltage	+200	mV

¹⁰The LMRK007X IMU supports both protocols (also called TIA/EIA-485) but does not support RS-485 with multiple devices connected to the same bus.

¹¹Same accuracy for CPU clock and serial communications.

¹²User selectable.

¹³The IMU has the ability to ignore tge RS-422/485 receiver 15 seconds after power-up.

¹⁴For a differential driver load of 100 Ω .

¹⁵Input resistance from A or B to common ground.

3.3 External Sync¹⁶

The LMRK007X IMU has a variable external sync rate up to 8 kHz for the standard product and up to 10 kHz for the VELOX[®] Plus option. The IMU message output occurs at the falling edge of the external sync signal to reduce jitter. If the falling edge happens too fast the message is output when processing is complete.

Specification	Value	Accuracy	Unit
Input Frequency ^{17,18}	$50 \leq F_{ExtSync} \leq 10,000$	N/A	Hz
Duty Cycle ¹⁹	$1 \leq \text{Duty} \leq 99$ (50 nominal)		%
Glitch Filter ²⁰	< 250	1/CCF ²¹	ns
Falling Edge of Ext. Sync to Transmit Time ²²	4	25	μs
Input/Common-Mode Voltage	$1.8 \leq 3.3 \leq 5.5$	N/A	V
Termination Impedance	5		k Ω

3.4 Self-Test

Parameter	Value	Variance	Unit
Gyroscope Shift	400	± 80	$^{\circ}/\text{s}$
Accelerometer Shift	10	± 2	g
Self-Test Response Delay	< 1	-	ms
Self-Test Glitch Filter	300	-	ns

¹⁶Ability to ignore the external sync signal available.

¹⁷The frequency of the external sync signal overrides the internal ODR while the external sync signal is present. This eliminates the internal over-sampling of the sensors, samples the sensors at the external sync frequency, and outputs message packets at the external sync frequency ($F_{ExtSync}$).

¹⁸The maximum external sync input frequency is 8 kHz with the standard product and 10 kHz with the VELOX[®] Plus option.

¹⁹External sync occurs at the rising edge of the signal while the falling edge is ignored. External sync initialization can take up to 30 sync edges depending on the timing accuracy between each pulse edge.

²⁰Any transitions from low to high and back to low that occur in < 50 ns are ignored. To be valid, the external sync signal pulse must be longer than 50 ns.

²¹Core Clock Frequency. See Section 4 for details.

²²Valid when the external sync high signal is > 60 μs . If the external sync high signal is < 60 μs , this value changes to 25 μs .

4 Firmware

Specification	Value	% Error	nUnit
Revision Number ²³	60.2.81.2	N/A	-
Start-Up Time			
Without External Sync	≤ 150	±10%	ms
With External Sync	≤ 250		ms
Stop Bits	1	N/A	-
Parity Bit	Even		-
Core Clock Frequency ²⁴ (CCF)	120	±100ppm typical ±200ppm max.	MHz

5 Timing

The table below shows the Baud rate and bandwidth available for each VELOX[®] tier of the LMRK007X SX2 IMU. For additional timing information contact sales@gladiatortechnologies.com.

Parameter	Standard	Plus	Variance	Unit
Max. Baud Rate	3	7.5	N/A	MBaud
Rising Edge of External Sync to Message Transmitted	160	115	25	μs
VELOX [®] Processing Time	80			

²³Effective 01/01/2021.

²⁴Same accuracy for CPU clock and serial communications. Deviation over voltage range and calibrated temperature range of the unit.

5.1 Message Transmission Delay

The transmission delay is a function of Baud rate. The table below shows the transmission delay for several Baud rate options.

Baud Rate	Message Delay (μ s)			% Error
	16-bit	24-bit	32-bit	
115 kBaud	1140	1425	1710	0.22
921 kBaud	144	180	216	0.36
1.5 MBaud	87.6	109.5	131.4	0.2
3 MBaud	44.4	55.5	66.6	
6 MBaud	21.6	27	32.4	
7.5 MBaud	18	22.5	27	

5.2 Baud Rate Resolution

The LMRK007X offers a variable Baud rate up to 7.5 MBaud that can be set to an arbitrary value governed by the equations below where CCF is the CPU core clock frequency (see Section 4 for details):

$$scale = INT\left(\frac{CCF}{16 * DesiredBaud}\right) \tag{1}$$

$$ActualBaud = \frac{2 * CCF}{scale + INT\left(\frac{CCF}{DesiredBaud} - 16 * scale\right) * 2}$$

The table below shows the nominal Baud rate and error for standard Baud rates offered by Gladiator:

Desired Baud	Actual Baud	% Error
115,200.00	115,218.43	0.02
921,600.00	923,076.92	0.16
1,500,000.00	1,500,000.00	0.00
3,000,000.00	3,000,000.00	
6,000,000.00	6,000,000.00	
7,500,000.00	7,500,000.00	

6 Message Protocol

Data Description	No. of Bytes ²⁵	Value
Start of Message	1	Variable
Message Counter	1	Mod 256 Counter (0-255)
Gyroscope X-Axis	2	Signed 16/24/32-bit integer
Gyroscope Y-Axis	2	Signed 16/24/32-bit integer
Gyroscope Z-Axis	2	Signed 16/24/32-bit integer
Accelerometer X-Axis	2	Signed 16/24/32-bit integer
Accelerometer Y-Axis	2	Signed 16/24/32-bit integer
Accelerometer Z-Axis	2	Signed 16/24/32-bit integer
Temperature	2	Signed 16-bit integer
Status Indicator ²⁶	1	Varies by message counter
Checksum	1	Two's Complement Sum

7 Power

Specification	Typical Value	Max. Value	Unit
Supply Voltage ²⁷	$+4.5 \leq V_{in} \leq +5.5$	+5.5	V
Power Consumption ^{28,29}	280	450	mW
Supply Current ²⁹	80	130	mA

²⁵A byte is defined as having 1 start bit, 8 data bits, even parity, and 1 stop bit. Thus, there are 11 bits of data transmitted/received per byte.

²⁶See the *Gladiator Technologies Software Reference Manual* or the *LMRK007X User Guide* for more details on message protocol descriptions.

²⁷Nominal input voltage is single-sided +5 V.

²⁸Representative of nominal input voltage of +5V, 3 Mbaud transmission rate.

²⁹ V_{IN} directly supplies the RS-485 transceiver and the external sync receiver. This can cause the supply power to vary with cable length.

8 Pin Configuration

The LMRK007X uses a custom 9-pin Omnetics connector. See Figure 3 for details.

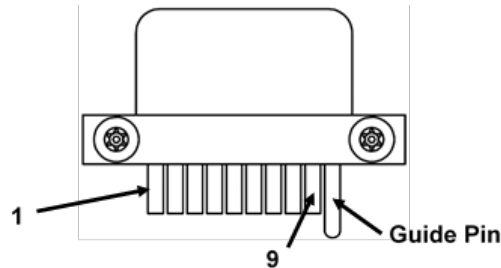

Figure 3: LMRK007X 9-pin Omnetics connector showing orientation to pin 1.

8.1 Single Input Ext. Sync (-300 Configuration)

Pin No.	Assignment	Twisted Pair Pin No.
1	RS-422/485 A (+)	1-2
2	RS-422/485 B (1)	
3	Power Ground	3-5
4	Not Connected	
5	Supply Voltage (V_{IN})	
6	External Sync Input ³⁰	6-7
7	Signal Ground	
8	Self-Test (3.3 V Logic)	-
9	Case	-

³⁰A high external sync signal at power-up disables the RS-422/485 receiver for 3 seconds. Additionally, an active external sync signal during operation disables the RS-422/485 receiver.

9 Axis Definitions

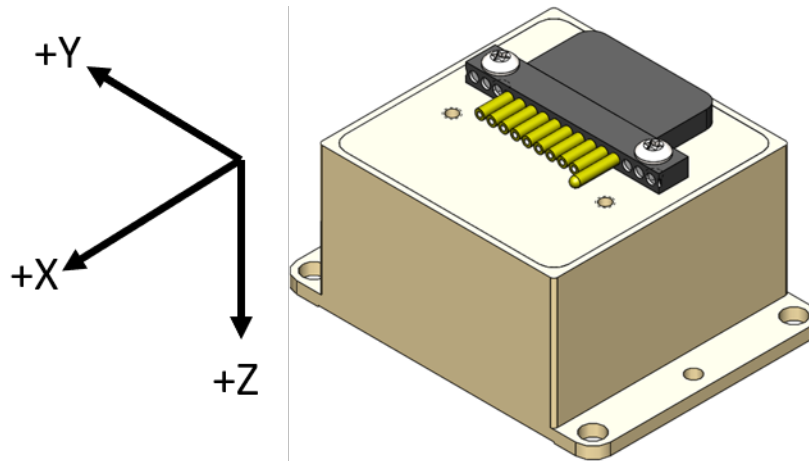

Figure 4: Positive axes for the LMRK007X IMU. Positive rotations are given by the right-hand rule.

10 Interfacing with the IMU

The customer can interface with the IMU using an SDK which plugs into a computer with a USB connection. Data is collected and the modes are adjusted with Gladiator's Glamr software. Contact sales@gladiatortechnologies.com for more details.

A Simplified Equivalent Input Diagrams

A.1 RS-485

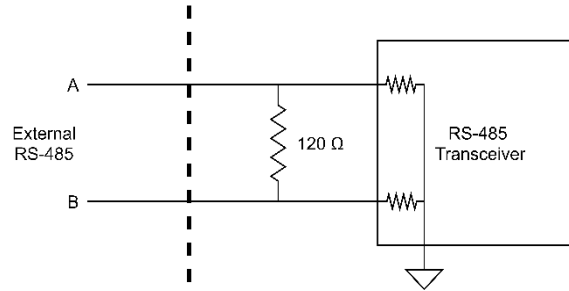

B Message Details

B.1 LMRK007X IMU

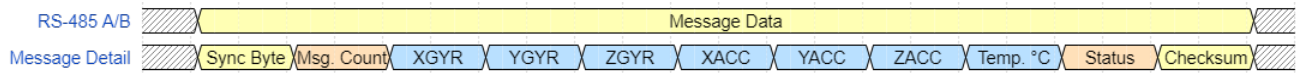

B.2 RS-485 Synchronized with External Sync

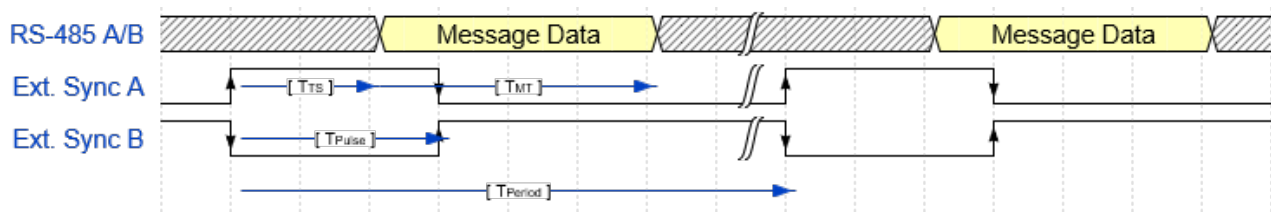

Figure 5: RS-485 message output synchronized with external sync. Timing values are approximate for a 3 MBaud transmission.

Parameter	Value			Unit
	Minimum	Typical	Maximum	
Transmit start time after rising sync pulse (T_{TS})	-	80	-	μs
Message transmission time (T_{MT})	-	76	-	μs
External sync pulse width (T_{Pulse})	50	$T_{period} * 0.50$	$T_{period} * 0.99$	ns
External sync period (T_{Period})	100	-	20,000	μs

C Contact Information

Email: support@gladiatortechnologies.com

Web: www.gladiatortechnologies.com

Telephone: 425.363.4180

Mail:

Gladiator Technologies
ATTN: Technical Support
8022 Bracken Place SE
Snoqualmie, WA 98065 USA

Revision History

Rev.	Date	Change Description	Page No(s).
A	January 12, 2021	Initial document created.	-

ALCYON
ÉLECTRONIQUE
Tel : +33 (0) 1 34 94 77 00
<https://alcyonelectronique.fr/>
commercial@alcyonelectronique.fr