

REVISIONS					
ZONE	ECN	REV.	DESCRIPTION	DATE	APPROVED
		NEW	ORIGINAL DRAWING	05/10/16	MEA
	DCR 276	A	UPDATED NOTE 5 ANODIZE COLOR TO BLUE FROM BLACK	03/27/2017	MEA

- NOTES:
- USE ESD PROTECTION WHEN HANDLING
  - PACKAGE WITH ESD SENSITIVE BAG
  - POWER VOLTAGE RANGE +7V TO +36V
  - WEIGHT:  $\leq 115g$
  - FINAL FINISH: BLUE ANODIZE PER MIL-A-8625 TYPE II, CLASS II
  - SHIPS WITH HARDWARE:
    - M4 x .7 x 12mm OR 8-32 x 1/2 SCREWS
    - M83513/05-05 JACK SCREWS
    - M83513/03-B03N 15 PIN MATING CONNECTOR

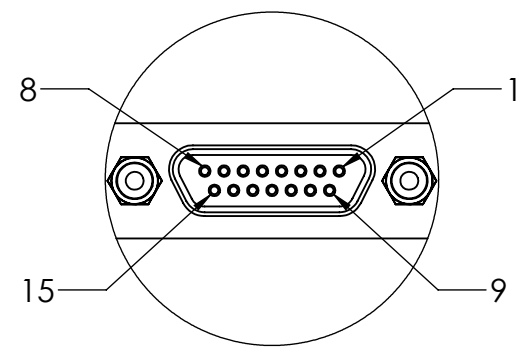

DETAIL A  
SCALE 2 : 1

PIN NO.	PIN ASSIGNMENT
1	RS-485 A (+)
2	RS-485 B (-)
3	POWER GROUND
4	ANALOG/ DIGITAL INPUT (0V - 5V)
5	+7V TO +36V INPUT POWER
6	EXTERNAL SYNC INPUT (5kHz OR 1pps)
7	+5V REGULATED OUTPUT
8	SIGNAL GROUND
9	SELF TEST
10	CANBUS HIGH
11	CANBUS LOW
12	CANBUS GROUND
13	NOT CONNECTED
14	NOT CONNECTED
15	CASE

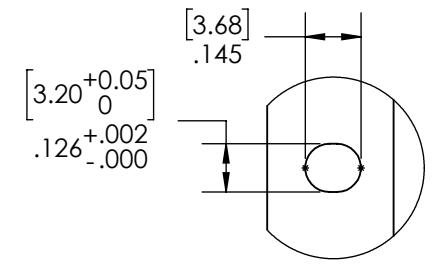
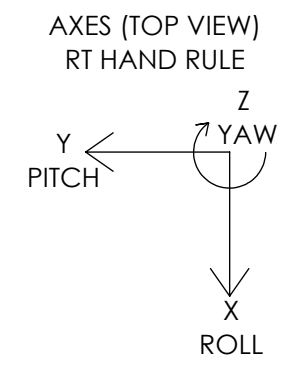

DETAIL B  
SCALE 2 : 1

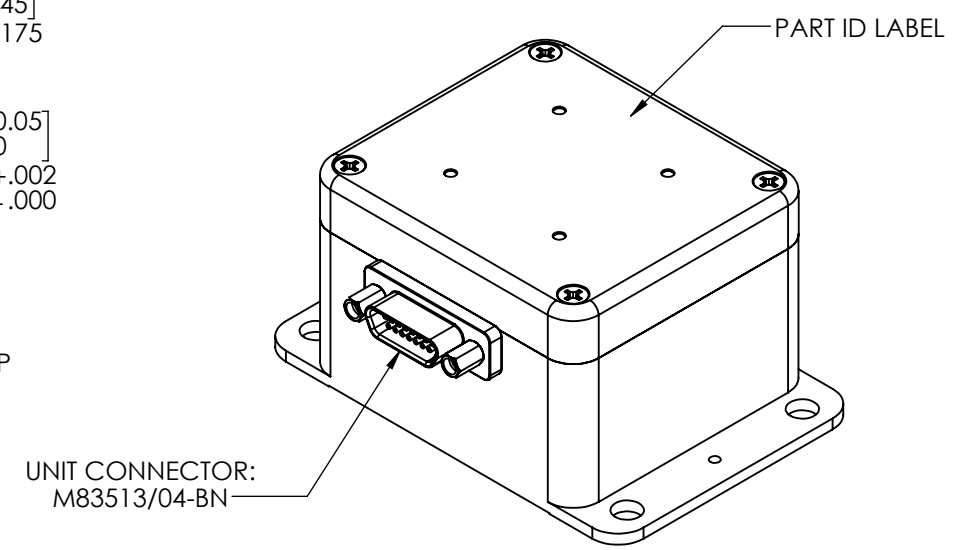
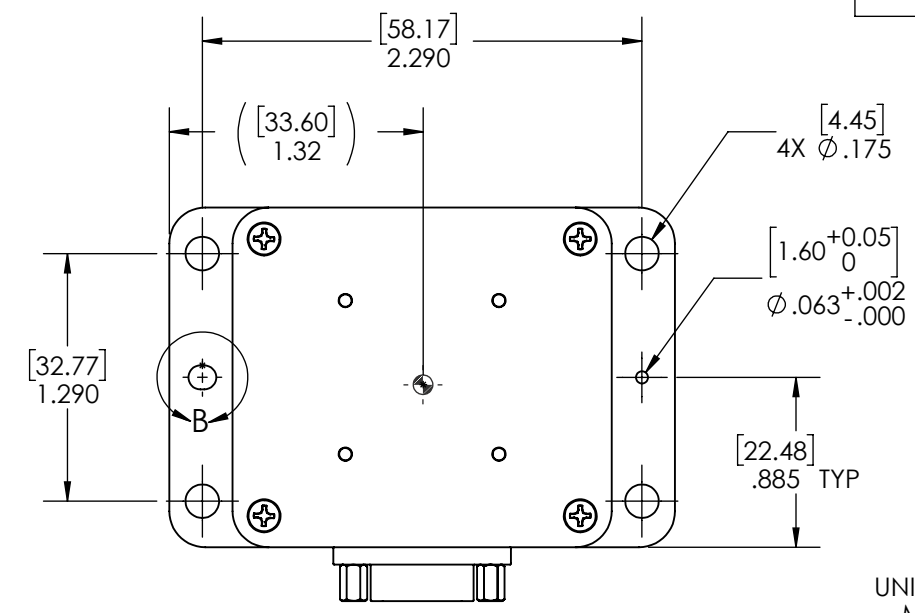

UNIT CONNECTOR:  
M83513/04-BN

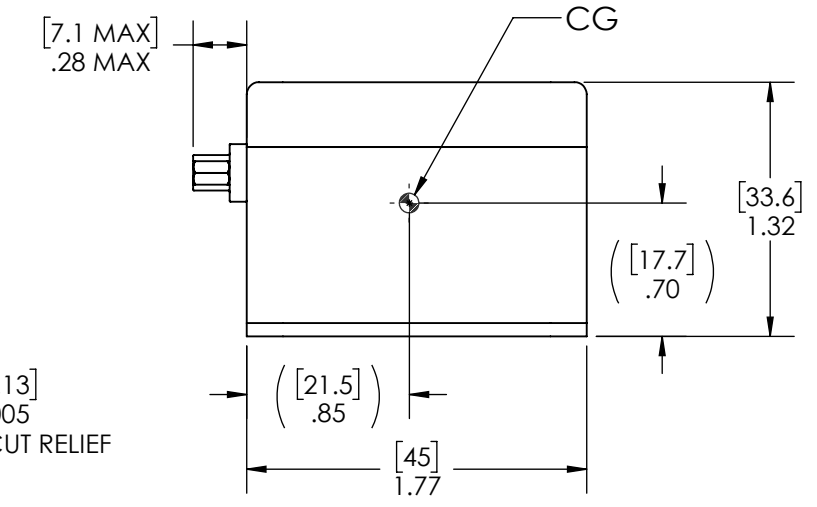
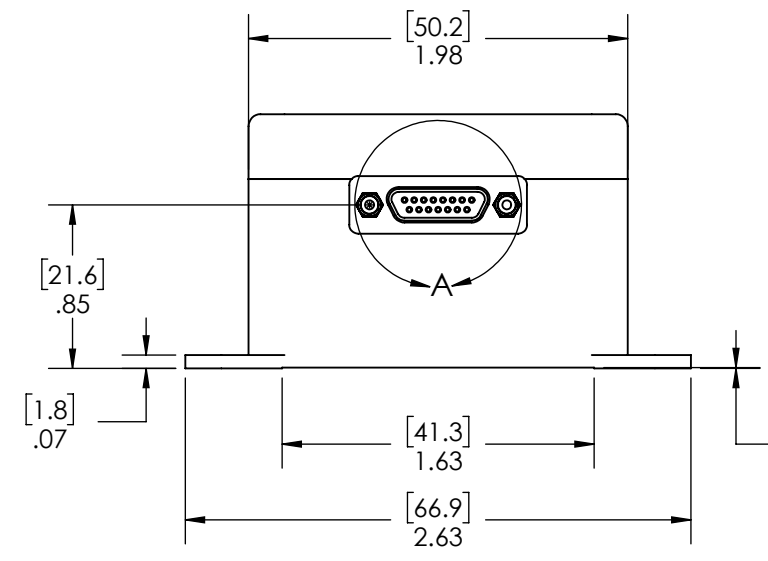

THIS DOCUMENT IS AN UNPUBLISHED WORK. COPYRIGHT 2017 GLADIATOR TECHNOLOGIES ALL RIGHTS RESERVED.

THIS DOCUMENT AND ALL INFORMATION AND EXPRESSION CONTAINED HEREIN ARE THE PROPERTY OF GLADIATOR TECHNOLOGIES AND ARE PROVIDED TO THE RECIPIENT IN CONFIDENCE ON A "NEED TO KNOW" BASIS. YOUR USE OF THIS DOCUMENT CONSTITUTES ACCEPTANCE OF THESE TERMS.

INFORMATION CONTAINED IN THIS DOCUMENT IS SUBJECT TO U.S. EXPORT LAWS AS DEFINED IN THE EXPORT ADMINISTRATION REGULATIONS (EAR) AND/OR THE INTERNATIONAL TRAFFIC AND ARMS REGULATIONS (ITAR). ILLEGAL EXPORT IS PROHIBITED.

Commercial Distribution Authorized per Commodity Classification ECCN7A994 (T-5 Countries Distribution Prohibited) Non-Technical Detail and is Non-ITAR

TYPED SIGNATURES CONSTITUTE APPROVAL. ACTUAL SIGNATURES ON FILE AT GLADIATOR TECHNOLOGIES IN SNOQUALMIE, WA



UNLESS OTHERWISE SPECIFIED		CONTRACT NO.		GLADIATOR TECHNOLOGIES SNOQUALMIE, WA	
ALL DIMENSIONS ARE IN INCHES AND ( ) METRIC - TOLERANCES UNLESS SPECIFIED ARE:	TOL.	.XX	±.01	DRAWN	JTZ 12/15/15
		.XXX	±.002	CHECKED	MEA 05/10/16
FINISH: SEE NOTES	INTERPRET DRAWING PER ASME Y14.100 BREAK ALL SHARP EDGES	ANGLE ±X°		MECH.ENG.	JTZ 12/15/15
		PRECIOUS METAL INDICATOR CODE A		Q.A.	KRM 05/10/16
		DASH NO. NEXT ASSY DWG APPLICATION		APPD.	MKC 05/10/16
TOP LEVEL		TITLE:		LMRK60-IMU OUTLINE	
SCALE:		CAGE CODE:		SIZE:	DWG. NO.
47L11		47L11		B	990-LMRK60-IMU
SHEET: 1 OF 1		REV.:		A	

