

CAPACITIVE DRIVER

CPL590

Capacitive Driver

- Digital Outputs
- USB, SPI and EtherCAT
- Small 2U Size
- Up to 4 Selectable Ranges on 1 Probe
- Best Linearity
- Higher Stability
- Digital Adjustment

Specifications

Resolution ¹ :	0.0005% @ 100 Hz
	0.003% @ 15 kHz
Selectable Bandwidth:	100Hz, 1, 10, 15kHz
Linearity ² :	<0.1% F.S. typical
Max Drift:	0.04% F.S./°C
Operating Temp:	4-50°C
Output:	±10V, 0Ω 10mA max
Rear-Panel:	SPI, EtherCAT

1. Dependent on probe, range, and bandwidth. See next page for details.

2. Dependent on probe and range. See next page for details.

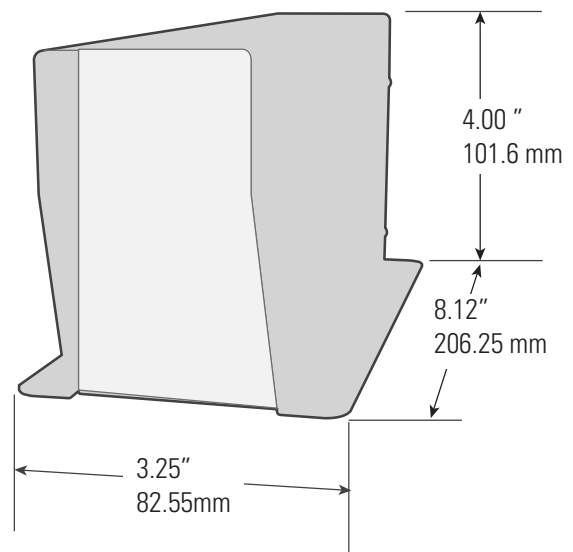

ALCYON
ÉLECTRONIQUE

RD 11 – BP20 – 78650 Beynes – France

Tel : +33 (0) 134 947 700

info@alcyonelectronique.fr

Fax : +33 (0) 134 875 340

www.alcyonelectronique.fr

Export License

May require an export license to some countries.

Selecting the Right Technology

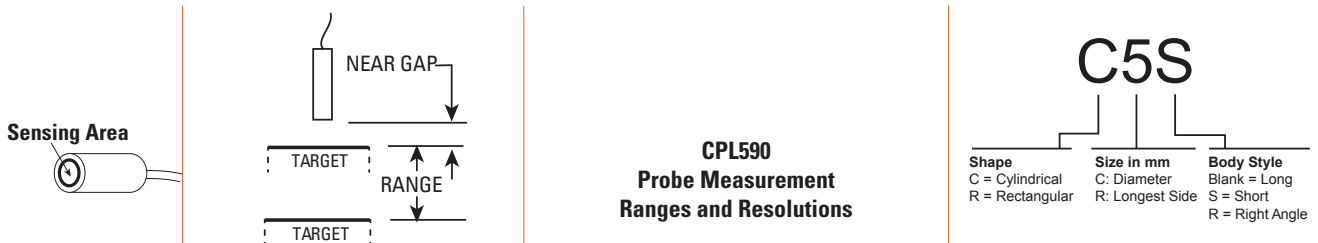

Sensing Area Diameter mm	Measurement Range			Resolution ¹ @ Bandwidth				Available Body Sizes	
	Range Type	Range μm mils	Near Gap μm mils	1 kHz nm μin	10 kHz nm μin	15 kHz nm μin	Linearity %FS	Models	Body Sizes
0.5	Fine	10 0.4	20 0.8	0.14 0.006	0.56 0.022	0.70 0.028	1.0	C3S C3R C5S C5R C5	
	Standard	50 2.0	50 2.0	0.70 0.028	4.2 0.17	5.6 0.22	0.50		
	Extended	80 3.0	60 2.4	1.4 0.056	7.0 0.28	—	0.50		
0.8	Fine	25 1.0	75 3.0	0.70 0.028	1.7 0.070	2.1 0.084	0.50	C3S C3R C5S C5R C5	
	Standard	100 4.0	100 4.0	1.4 0.056	4.9 0.20	7.0 0.28	0.50		
2.0	Ultrafine	10 0.4	20 0.8	0.11 0.004	0.21 0.008	0.35 0.014	1.0	C5S C5R C5 C8S C8R C8	
	Fine	50 2.0	75 3.0	0.42 0.017	0.84 0.034	1.4 0.056	0.30		
	Standard	250 10.0	125 5.0	0.56 0.060	5.6 0.22	7.0 0.28	0.30		
	Extended	500 20.0	125 5.0	4.2 0.17	11 0.44	14 0.56	0.30		
3.2	Fine	50 2.0	125 5.0	0.56 0.022	1.4 0.056	2.2 0.073	0.30	C8S C8R C8	
	Standard	500 20.0	250 10	4.2 0.17	8.4 0.37	14 0.56	0.30		
	Extended	1250 50.0	250 10	21 0.84	28 1.1	42 1.7	0.30		
5.6	Fine	50 2.0	225 9.0	0.56 0.022	1.1 0.44	1.8 0.072	0.30	C9.5S C9.5R C9.5 R20	
	Standard	500 20.0	500 20	4.2 0.17	9.8 0.39	14 0.56	0.30		
	Extended	2000 80.0	250 10	14 0.56	28 1.1	42 1.7	0.30		
13	Fine	2000 80	2000 80	42 1.7	49 4.2	56 2.2	0.50	C18	
	Standard	3200 125	2000 80	56 2.2	70 2.8	84 3.4	0.50		
	Extended	5000 200	3000 120	140 5.6	180 7.3	210 8.4	0.50		
19	Standard	2500 100	5000 200	100 3.9	100 5.0	140 5.6	0.50	R45	
	Extended	6000 250	3000 120	170 6.7	100 9.0	250 10	1.0		
21	Standard	8000 300	5000 200	140 5.6	180 7.3	210 8.4	0.50	C25	
	Extended	12500 500	5000 200	250 10	320 13	350 14	0.50		

Resolution values are RMS. Peak-to-peak values are typically 8-10 times greater than the RMS values.
In high EMI conditions (10 V/m) output DC level may shift and noise may rise to 0.2 VRMS (1.3% resolution).