

DC Axial Fan
TUDC



□60×25 (□2.4"×1.0")
Max. airflow: 0.87 m³/min
Max. static pressure: 130 Pa
Mass: 75 g

Fan model code

- TUDC12B4
- TUDC12B4F
- TUDC12B4S
- TUDC12D4
- TUDC12D4S
- TUDC12H4
- TUDC12H4S
- TUDC12N7
- TUDC12Z4
- TUDC12Z4F
- TUDC12Z4FS
- TUDC12Z4P
- TUDC12Z4Q
- TUDC12Z4S
- TUDC24B4
- TUDC24B4S
- TUDC24D4
- TUDC24D4S
- TUDC24H4
- TUDC24H4S
- TUDC24S7
- TUDC24S7F
- TUDC24Z4
- TUDC24Z4P
- TUDC24Z4S
- TUDC24Z4SQ
- TUDC48H4

Standard specification

Max. Airflow m ³ /min	Max. Static Pressure CFM	Max. Static Pressure		Noise dB	Speed min ⁻¹	Input W	Voltage Spec. V		Current mA		Model Code		Operating Temp. Range °C
		Pa	inH ₂ O				Rating	Operating Range	Rating	Starting	Open Flange	Ribbed Flange	
0.9	32	150	0.60	44	6900	4.8	24	12-27.6	200	750	TUDC24S7F	TUDC24S7	-20 ~ +60
0.87	31	130	0.52	46	6800	4.2	12	7.2-13.8	350	1430		TUDC12N7	
0.65	23	75	0.30	37	5000	2.6	12	7.2-13.8	220	710		TUDC12H4	-20 ~ +60
							24	12-27.6	110	360		TUDC24H4	
0.55	19	59	0.24	32	4300	1.8	12	7.2-13.8	140	550	TUDC12Z4F	TUDC12Z4	-20 ~ +70
							24	12-27.6	80	270		TUDC24Z4	
0.47	17	39	0.16	27	3650	1.4	12	7.2-13.8	130	380	TUDC12B4F	TUDC12B4	-20 ~ +70
							24	12-27.6	70	190		TUDC24B4	
0.35	12	24	0.10	20	2750	0.9	12	8.4-13.8	80	210		TUDC12D4	-20 ~ +70
							24	14.4-27.6	40	110		TUDC24D4	

- Figures in the table are average measured values. Please request the product delivery specification when preparing a purchase specification.
- The characteristics are the values at rated voltage (12 V, 24 V or 48 V), and normal temperature and humidity.

General specification

Materials Used	Venturi: ABS and PBT synthetic resins Propeller: ABS and PBT synthetic resins Bearing: Both side shielded ball bearing
Motor	Brushless DC motor, Protection type: Current shut off by detecting lock state, automatically reset
Common Elec. Spec.	See pages G-11, G-12, G-13.
Standard Carton	100 to a carton of (450 x 380 x 160) mm, mass 9 kg

● Venturi shape

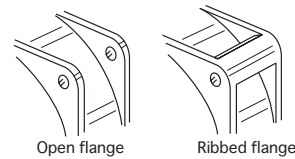

Specify no suffix symbol in your ordering information when the venturi is mounted with screws. Suffix 'F' for an open flange venturi.

Standard airflow and static pressure characteristics (At rated voltage)

[By double chamber method]

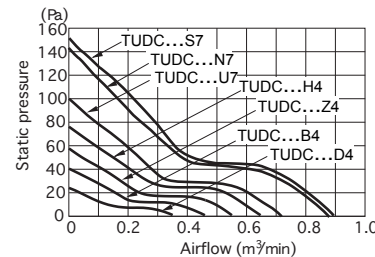

External dimensions in mm (inches)

- Lead wire type Lead wire spec. AWG24 UL1007 or UL3266
Color (+) Red (-) Black (TUDC□D4: Blue)

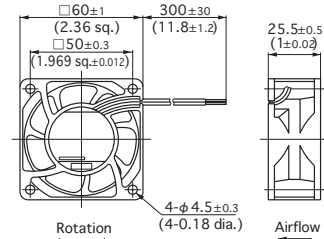

Wiring connection diagram

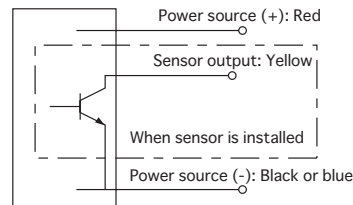

Mounting hole dimensions [Recommendation]

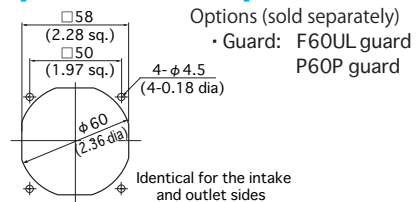

DC axial fan with sensor

Rated Vol.	Model Code			
12 V	TUDC12D4S	TUDC12B4S	TUDC12Z4S TUDC12Z4FS TUDC12Z4P TUDC12Z4Q	TUDC12H4S
24 V	TUDC24D4S	TUDC24B4S	TUDC24Z4S TUDC24Z4SQ TUDC24Z4Q	TUDC24H4S
48 V			TUDC48Z4P	

- NIDEC SERVO can meet many of your requirements for customization, such as special connectors, other sensors not listed above, variable speed specifications, and other modifications. Please contact NIDEC SERVO during your product planning and development stage.
- The listed products are registered in the following overseas standards files, UL: E48889, CSA: LR49399, TUV: R9451586
- Customizing to the sleeve bearing specification also accepted depending on the intended purchase quantity. Contact NIDEC SERVO for further information.
- 3D data is also available at our site.

F60P Guard (Mass 4 g)

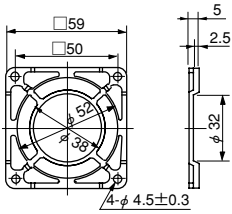

Material: Polycarbonate (black)
UL94V-2

F60UL Guard (Mass 12 g)

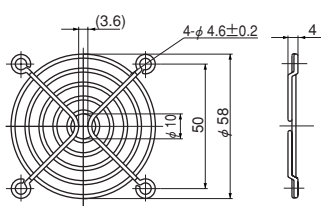

Material: Mild steel wire 1.6 dia.
Surface treatment:
Nickel chromium plating

F80UL Guard (Mass 14 g)

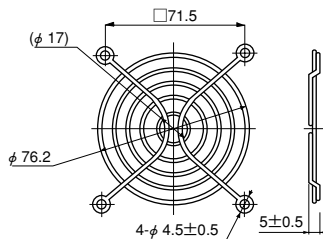

Material: Mild steel wire 1.6 dia.
Surface treatment:
Nickel chromium plating

F92UL Guard (Mass 16 g)

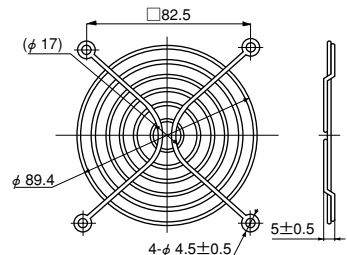

Material: Mild steel wire 1.6 dia.
Surface treatment:
Nickel chromium plating

F120UL Guard (Mass 29 g)

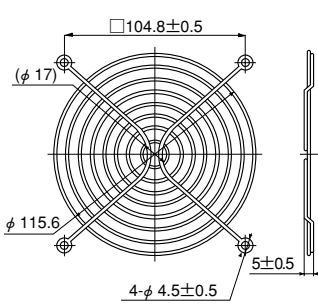

Material: Mild steel wire 1.6 dia.
Surface treatment:
Nickel chromium plating

F127UL Guard

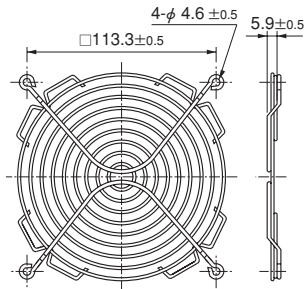

Material: Mild steel wire 1.6 dia.
Surface treatment:
Nickel chromium plating

GUARD 172

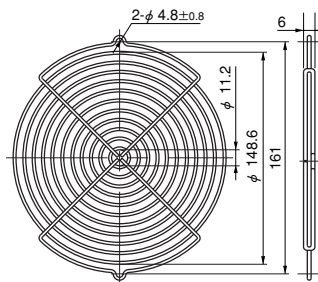

Material: Mild steel wire 2 dia.
Surface treatment:
Nickel chromium plating

F180UL Guard

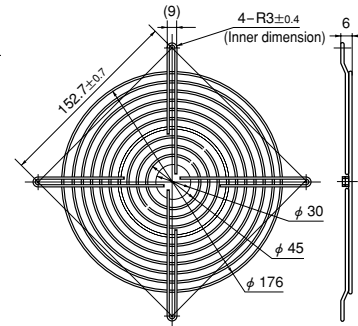

Material: Mild steel wire 1.6 dia.
Surface treatment:
Nickel chromium plating

F200UL Guard (Mass 82 g)

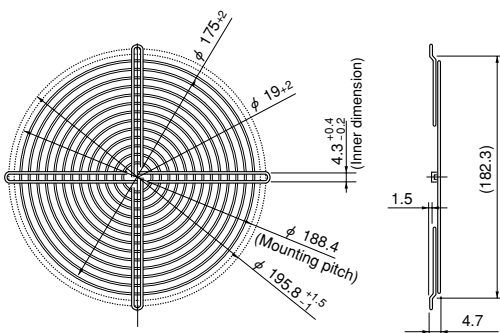

Material: Mild steel wire 1.6 dia.
Surface treatment:
Nickel chromium plating

SCN Guard (Mass 55 g)

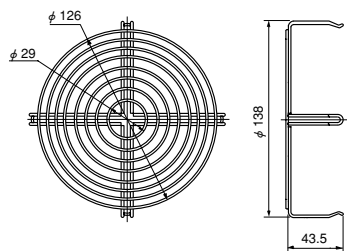

Material: Mild steel wire 1.6 dia.
Surface treatment:
Nickel chromium plating

- Guard special for intake side of SCN (metal venturi) fans.

List of mating fan series

Guard	F60P	F60UL	F80UL	F92UL	F120UL	F127UL	GUARD 172	F180UL	F200UL	SCN
SCN					○*1					○*2
AC Axial Fans			○	○						
VE			○							
WE				○						
KA				○						
CU					○					
CN					○					
MA							○			
PA							○			
DC Axial Fans	○	○	○	○	○	○	○	○	○	○
TUDC	○	○								
PUDC			○							
KUDC				○						
DO925C				○						
KLDC				○						
CUDC					○					
D1225C					○					
DC Axial Fans										
CNDC					○					
D1238T					○					
D1238B					○					
D1338B						○				
D1338S						○				
D1751M							○			
D1751S							○			
G0638D		○								
G0838C			○							
G0938B				○						
G1238B					○					
G1751M								○		

*1: Can be installed only on outlet side. *2: Can be installed only on intake side. All guards conform to the UL standard when combined with NIDEC SERVO fans. The installation of a filter, guard and other accessories will constitute a ventilating load, reducing the airflow. Select a suitable guard, taking into consideration the increase in air resistance. (See Figs. 12 and 13 on page G-7.)

DC axial fans & blowers with sensors

The DC fans and blowers of NIDEC SERVO have a function to send an alarm signal when the fan motor revolutions slow down. Several systems are used to cut off the system power supply by this alarm signal, with three types of sensors available. Select the right type of sensor in accordance with the purpose of use. The lead wire for the sensor is yellow. The output type is an open collector output for all three types.

■ Sensor type

1. Lock detection type (Product code: S)

The output signal indicates an [L] state (transistor is ON) while the propeller is rotating, changing to an [H] state (transistor is OFF) less than five seconds after the propeller stops rotating. The propeller automatically restarts operation within five seconds when the lock is unlocked. ([H] → [L] 5 s). If the pull-up voltage is live, the [H] state (transistor is OFF) will engage in less than five seconds, even when the power is turned off.

- Specification: VCE = 28 V max (55.2 V max for 48 V products)
IC = 5 mA max
(VCE (SAT) = 0.4 V max)
- Output waveform

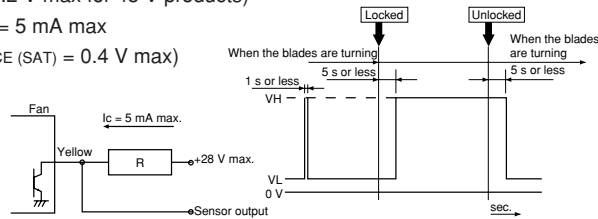

※When the power is turned on, the state sometimes becomes high [H] for several hundred ms.

2. Pulse output type (Product code: P)

A rectangular wave of two pulses will be output for each turn of the propeller while the propeller is rotating, outputting two types of signal depending on the propeller position when the propeller is locked. (See the note below ※)

- Specification: VCE = 28 V max (55.2 V max for 48 V products)
IC = 5 mA max
(VCE (SAT) = 0.4 V max)
- Output waveform

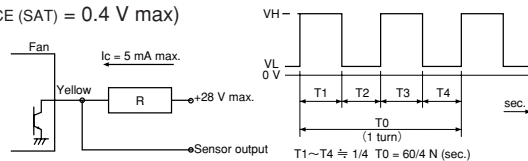

※Output signal waveform when the fan is stopped: The following two types of waveform are output, depending on the blade position when the propeller is stopped:
Pulse outputs of High - constant or restart timing (0.05 Hz to 2 Hz).

3. Speed detection type (Product code: Q)

The output signal indicates the [H] state when the propeller revolutions are slower than the preset speed, changing to the [L] state when the propeller revolutions exceed the reset speed.

[Products with a reversed output waveform are also available, suitable for a wired OR connection when several fans are installed. Contact NIDEC SERVO for further information. {Former code: SQ, new code (15 - digit code products): R}]

- Specification: VCE = 28 V max (55.2 V max for 48 V products)
IC = 5 mA max
(VCE (SAT) = 0.4 V max at 5 mA)

● Output waveform

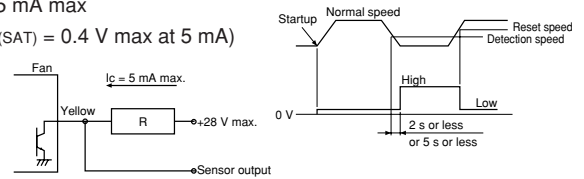

Note: The output waveform for type SQ (R) will be reversed. The speed setting for the alarm output is about half the rated speed. For more detailed information, please request a product delivery specification from NIDEC SERVO.



RD 11 – BP20 – 78650 Beynes – France

Tel : +33 (0) 134 947 700

info@alcyonelectronique.fr

Fax : +33 (0) 134 875 340

www.alcyonelectronique.fr