

N P M E U R O P E . C O M



Linear Shaft Motor

NPM

Nippon Pulse
Your Partner in Motion Control

N P M E U R O P E . C O M

Linear Shaft Motor

Linear Shaft Motor - The Next Generation Actuator

Nippon Pulse's family of Linear Shaft Motors are the next generation linear brushless motor. When reliability, zero maintenance, zero cogging and precision are paramount, the Linear Shaft Motors from Nippon Pulse are an ideal component choice, offering the user uncompromised performance, ease of use, compact package size and high value.

What is a Linear Shaft Motor?

The Linear Shaft Motor is a high precision direct drive linear servomotor consisting of a shaft of rare Earth-Iron-Boron Permanent Neodymium Magnets and a "forcer" of cylindrically wound coils which can be supplied with optional Hall effect devices. The shaft supplies the magnetic field which the forcer acts upon. The forcer assembly, combined with the amplifier and control electronics, produces the force for the motor. The Hall effect devices can be supplied, if they are required by your selected servo driver for proper commutation of a brushless linear motor, and are integrated into the forcer assembly.

The Linear Shaft Motor was designed with three basic design concepts:

- Simple - High Precision - Non Contact -

Linear Shaft Motors are simple. They consist of only two parts, a magnetic shaft and a "forcer" of cylindrically wound coils.

Linear Shaft Motors provide ultra-high precision. They have no iron in the forcer or shaft for precision and zero cogging. The coils of the Linear Shaft Motor form the core, providing the stiffness expected in an iron-core motor.

Linear Shaft Motors are non-contact. Since the coil completely wraps around the magnets, all the magnetic flux is efficiently used. This allows for a large (0.5 to 5.0mm) nominal annular air gap. This air gap is non-critical, meaning there is no variation in force as the gap varies over the stroke of the device.

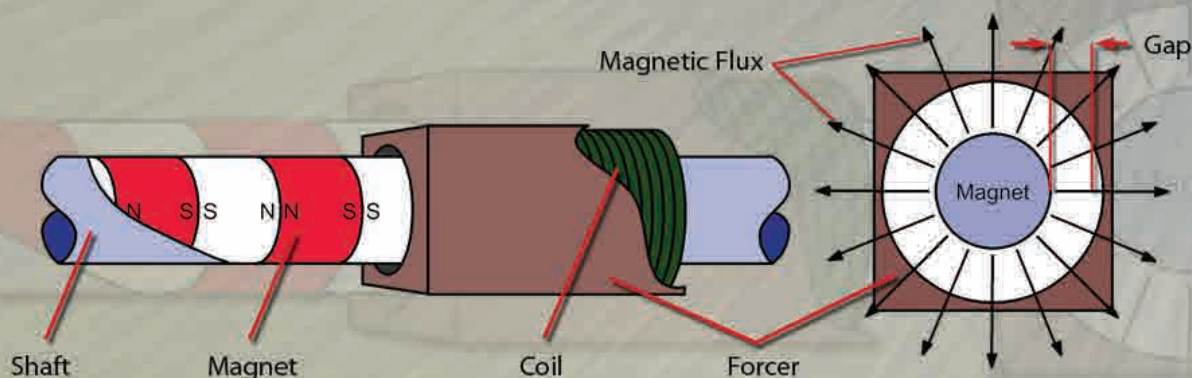

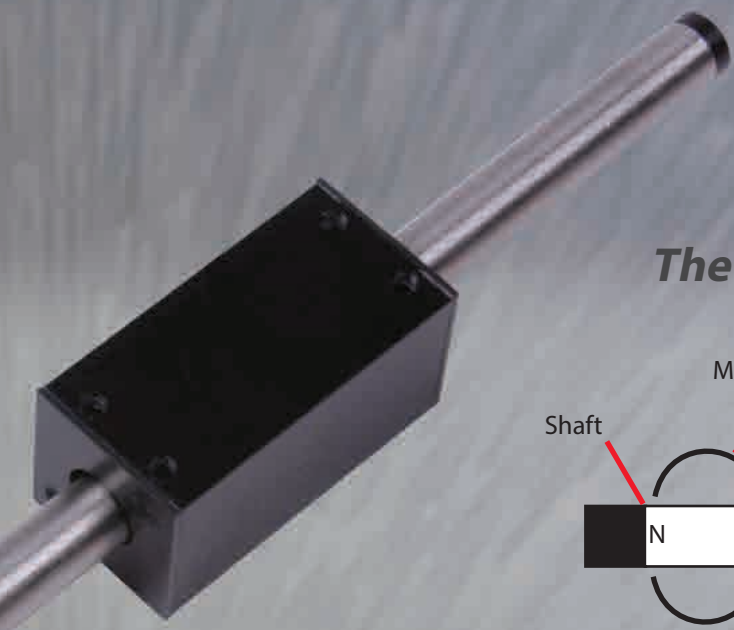

The Next Generation of Linear Motors

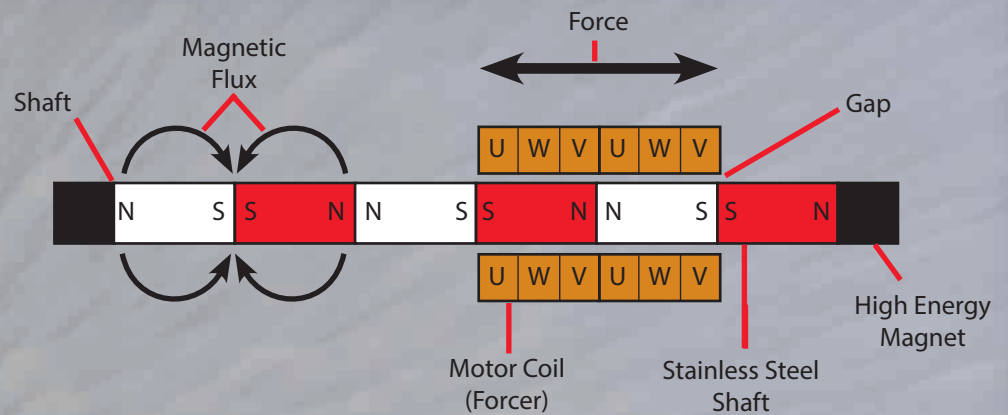

Basic Structure of a Linear Shaft Motor

The magnetic structure of the Shaft is built in such a manner that there is no space between each magnet; it is fully supported within itself. The magnetic structure is then inserted into a protective stainless-steel tube. This process is protected by numerous patents. This patented process produces a very strong magnetic field twice that of other linear motors.

Forcer Construction

The coils of the Linear Shaft Motor are of a cylindrical design, providing a number of key advantages over other linear motors.

- The cylindrical design of the coil assembly is very stiff without external stiffening materials (i.e. iron used by platen-style linear motors).
- The coils surrounding the magnets allow for the optimal use of all the magnetic flux. This makes the air gap non-critical. As long as the forcer does not come in contact with the shaft, there is no variation in the linear force.
- The magnetic flux cuts motor windings at right angles for maximum efficiency.
- All sides of the coil are positioned to allow for maximum dissipation of heat.
- The more efficient Linear Shaft Motor requires less power in a compact design while producing a comparable force to that of a similarly sized traditional linear motor.

Features of Linear Shaft Motors

- Capable of high thrust (up to 100,000N)
- Quiet — due to the absence of friction, the only mechanical contact section is the linear guide (Fully non-contact operation is possible using an air slider)
- Simplified unit construction allows a stroke of up to 4.6 meters
- High precision (0.07nm)¹
- High speed drive (greater than 10m/s) with acceleration up to 20G
- Low speed drive (8µm/s)
- Allows for parallel drive using only one encoder and one driver²
- Virtually no speed fluctuation (±0.006% at 100mm/s)
- Durable construction, capable of operation even underwater or in a vacuum

¹The precision of repetitive positioning is dependent on the resolution of the linear encoder. In addition, it is necessary to have sufficient machine rigidity. Also, absolute positioning precision is fundamentally dependent on the linear encoder. It is not dependent on the expansion or contraction caused by the heat of the Linear Shaft Motor.

Linear Shaft Motor

Traditionally, linear electric motors have been designed by “opening out flat” their rotary counterparts. For every rotary motor there is a linear motion counterpart, although the opposite of this statement may not always be true. Thus, corresponding to the DC motor and AC induction, stepper and synchronous motor, we have the Linear DC Motor (DCLM), Linear Induction Motor (LIM), Linear Pulse Motor (LPM), and Linear Synchronous Motor (LSM), respectively. Although this does provide a solution, a number of inherent disadvantages arise.

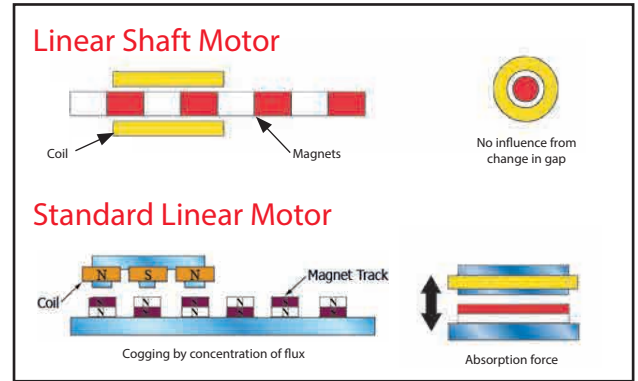

Like the voice coil motor, the force velocity (FV) curve of the Linear Shaft Motor is a straight line from peak velocity to peak force. The Linear Shaft Motor’s FV curves are split into three regions. The first is what we call Continuous Force. It is the region in which the motor can operate indefinitely without the need for any external cooling, including heat sinks. The second is Acceleration Force, which is the amount of force that can be delivered by the motor for 40 seconds without the need for any external cooling. The third region, the Peak Force, is limited only by the power which can be supplied and the duty cycle. It is limited to 1 to 2 seconds. Your local Nippon Pulse application engineer can help you map this for your particular application.

The Linear Shaft Motor is a very simple design that consists of a coil assembly (forcer), which encircles a patented round magnetic shaft. This design offers a number of advantages when compared to other types of linear motion systems:

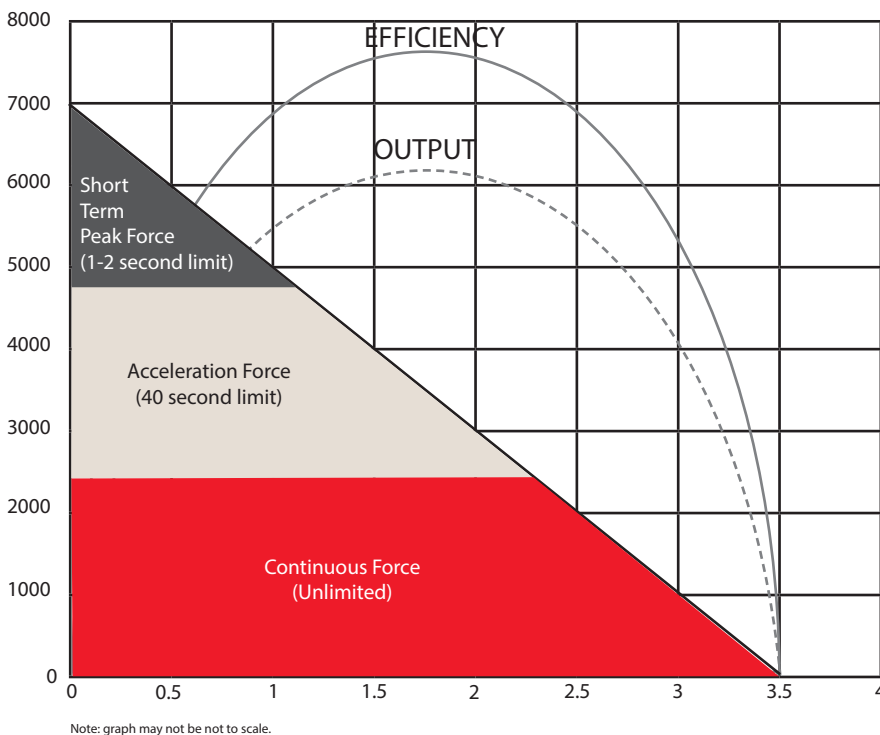

No Need for Precision Air Gap

Unlike other types of linear motor technologies, the cylindrical design of the Linear Shaft Motor contains a very large (0.5 to 5.0mm) non-critical air gap. This allows for a constant linear force, which is not affected by the alignment or misalignment of the forcer (coil) to the shaft (magnets). This allows for quick and simple assembly into the final product without the need for extensive machining and alignment time.

High Efficiency

The patented shaft design and resulting magnetic field allow for an unparalleled magnetic field strength. This allows a small amount of current to produce large amounts of force. The cylindrical design allows for 100 percent of the copper, current, and magnetic field to produce force in the direction of travel.

Coreless Design with Ultra-High Stiffness

Platen-style linear motors boast high levels of stiffness due to iron cores. This iron also results in the creation of Eddy currents, which generate large amounts of heat while allowing moderate amounts of heat dissipation. The iron core also introduces large amounts of absorption forces between the stator and armature, and cogging into the linear motion. U-shaped linear motors, on the other hand, have cores of epoxy, which does not create Eddy currents or any absorption force. This type of motor has a stiffness that is, at best, 1/125 that of a similar iron-cored motor. The sandwiching of the coil between the magnetic track and the very low thermal conductivity of epoxy produces a very thermally limited motor. The Linear Shaft Motor is designed to have a motor stiffness 100 times better than that of the U-shaped motor, while dissipating heat at a rate of four times that of similar sized Platen-style linear motors.

Linear Shaft Motor Advantages

- Compact & Lightweight: Lower weight when compared to traditional type of linear motors
- Zero Cogging: The coreless, ironless design results in no magnetic cogging
- Large Air Gap: The non-critical 0.5 to 5.0mm nominal annular air gap allows for easy installation and alignment
- Highly Efficient: Some of the highest efficiencies of any linear motor¹
- Enclosed Magnets: Easy integration into a number of environments
- Efficient Use of Magnetic Flux: Forcer encircles the magnets, allowing full use of the magnetic flux

¹ An independent study by the University of Virginia (Oct. 2010) shows, when all factors are equal, the Linear Shaft Motor is at least 50 percent more efficient than U-shaped linear motors.

Linear Stepping Motors

- Open loop or low servo stiffness
- Limited force/speed

Platen-Style Linear Motors

- Precision air gap required
- Large force between stator and armature
- Exposed magnet track

Piezo Motors

- Side loading
- Constant contact results in wear
- Audible noise generated
- Custom electronics needed

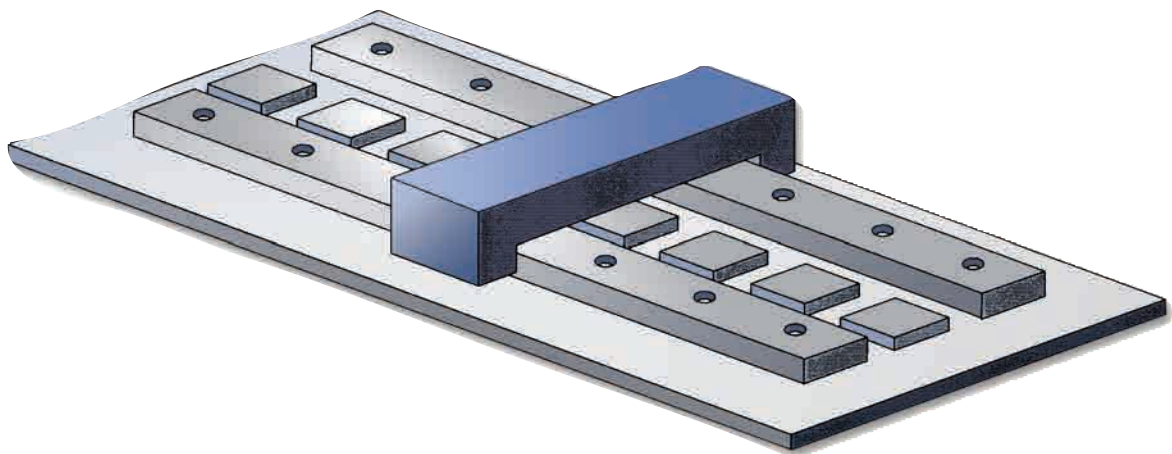

Linear Induction Motors

- Large physical size
- High power consumption
- Complex cooling typically required
- Large force between stator/armature

U-shaped Linear Motors

- Restricted heat dissipation from sandwiched armature coils
- Partial use of magnetic flux in design
- Limited mechanical stiffness

Linear Shaft Motors provide direct thrust for the positioning of the payload.

They eliminate the need for a rotary-to-linear conversion mechanism.

Examples: ball-screw, rack and pinion, toothed belt.

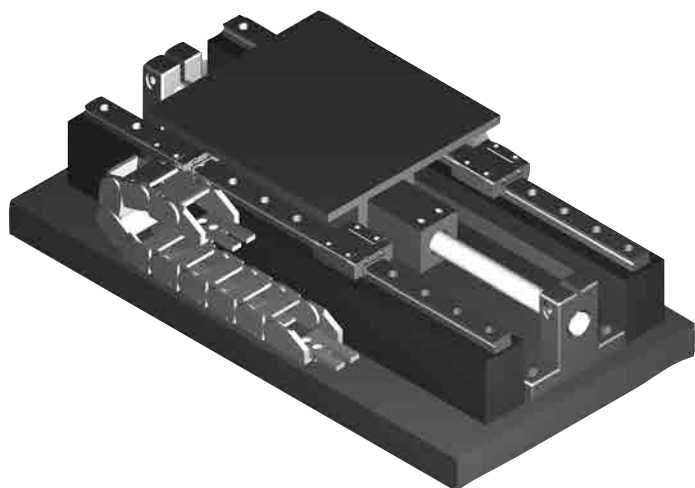

No Lubrication or Adjustment Maintenance Necessary

The Linear Shaft Motor requires no greasing, and has no performance degradation because of wear or aging, as with ball-screw and belt drive systems. Because the Linear Shaft Motor is maintenance-free, there is significant cost reduction throughout its lifespan. The air gap between the shaft and theforcer eliminates the need for adjustments such as positioning of the guide or concentric adjustment, which are all required for ball-screw systems.

No Noise and No Dust Operation

Dust and noise, inevitable in ball-screw and pneumatic systems, do not exist in the non-contact Linear Shaft Motor. This is not only applicable for clean room environments; it also greatly improves the work environment by reducing noise and dust.

Speed Fluctuation

High Speed (Velocity: 100mm/Sec)

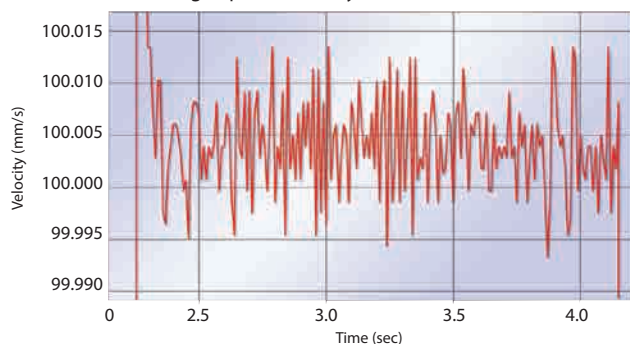

Low Speed (Velocity: 5mm/Sec)

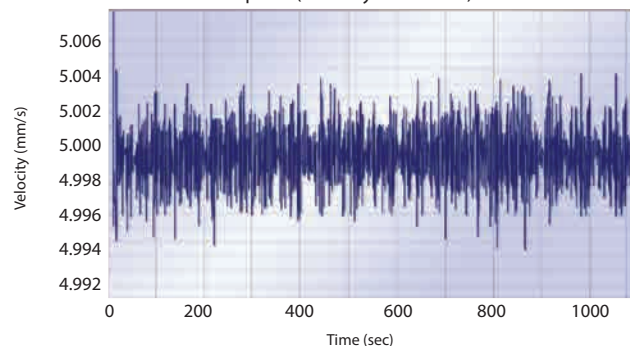

The Linear Shaft Motor is coreless and, as a result, is able to provide uniformity of speed.

Advantages of Linear Shaft Motors

- | | |
|---------------------------------|--|
| • Simple mechanical arrangement | Minimal number of moving parts |
| • Direct thrust motor | No backlash, no wear |
| • Wide speed range | 8µm/sec to >10m/sec |
| • Smooth | Virtually no speed fluctuation |
| • Quiet | Virtually silent motion |
| • Maintenance-free motor | No internal moving parts |
| • Lower inertia | Less mass to move |
| • Lower power requirements | Direct drive systems are more efficient than coupled systems |

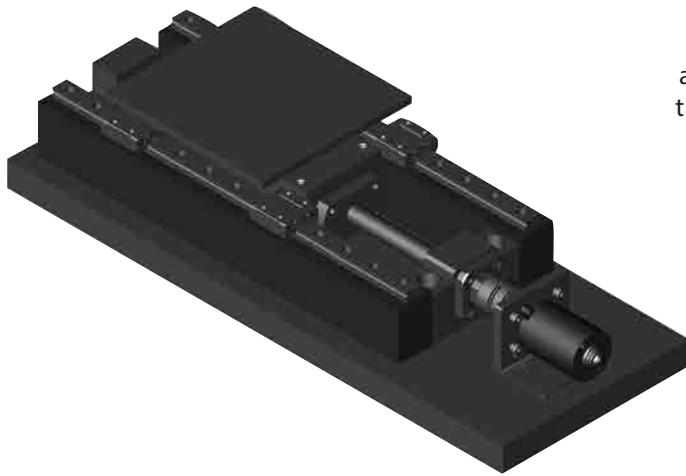

Extremely High Precision¹, Low Speed Uniformity and High Repeatability

The Linear Shaft Motor enables a level of precision not achievable in ball-screws, and allows you to drastically improve the yield of high precision processes, which are limited by other linear mechanisms.

Realizes High Speed Motions while Retaining High Precision

The Linear Shaft Motor's accuracy in high-speed operation shortens the travel time required by ball-screws.

Resistance Against Environmental Change

For precision operation, other linear mechanisms require strict control of work environment, including temperature control. The Linear Shaft Motor, which operates without direct contact, allows constant precision unaffected by environmental changes. This facilitates a large reduction in climate-control cost.

Precision

Static Positioning Performance (encoder resolution 8.6nm)

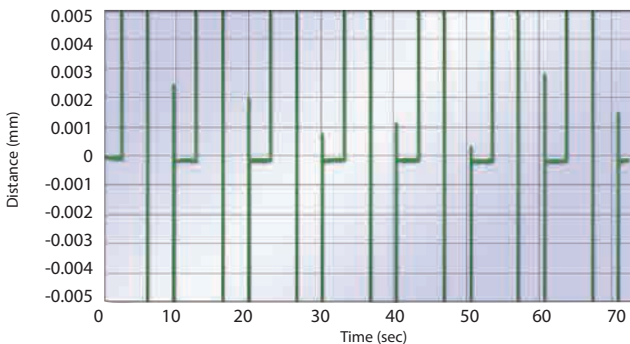
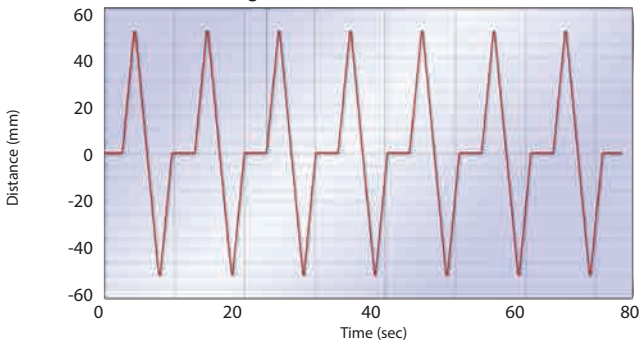

This is the center section of the top graph displayed at 10,000X magnification.

Using Linear Shaft Motors Can:

- Reduce the number of parts
- Save space
- Eliminate the need to adjust with locating guides and concentrics
- Reduce base machining costs and time
- Lower design costs and time

¹ The accuracy of repetitive positioning is dependent on the resolution of the linear encoder. It is necessary to have sufficient machine rigidity. Absolute positioning precision is fundamentally dependent on the linear encoder. It is not dependent on the expansion or contraction caused by the heat of the Linear Shaft Motor.

A wide range of applications are possible by utilizing one or more of the features of the Linear Shaft Motor.

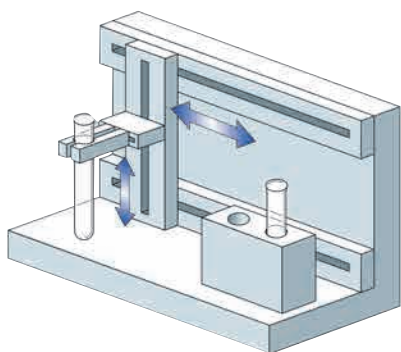

Friction-free and quiet

The Linear Shaft Motor's moving parts are all non-contact. All sources of noise and friction are eliminated, allowing use in quiet surroundings, such as test laboratories and medical facilities.

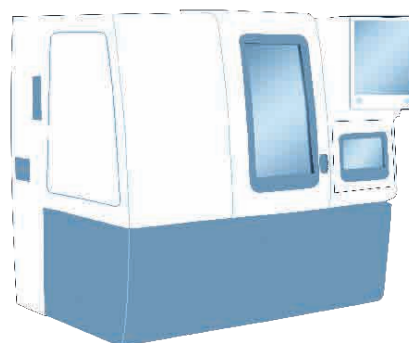

High thrust

Peak thrust of up to 100,000 Newtons is achievable. This can be used to precisely convey heavy loads such as clinical equipment, machine tool, or transfer lines on a factory floor.

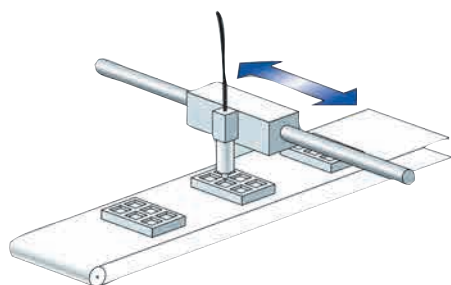

Environmental compatibility

Operates well in a vacuum and in production locations where oil or water are factors.

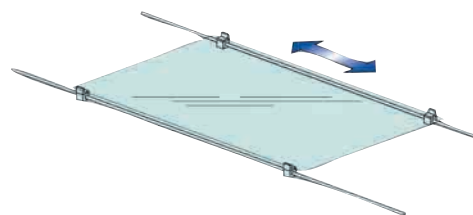

Large stroke lengths

Stroke lengths up to 4.6 meters. Ideal for high-precision conveying, such as LCDs over relatively long distances.

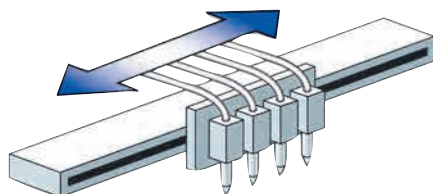

High controllable speed

Speeds greater than 10 meters/second have been documented. Ideal for line head drives in high-speed printers.

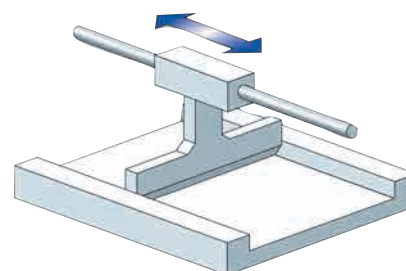

Low speed drives

Speeds as low as 8 μ m/second have been documented. Ideal for equipment that may be difficult to handle with ball-screws, such as life sciences equipment.

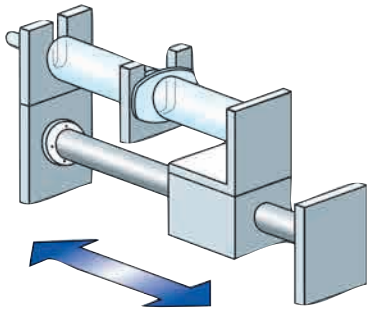

No speed fluctuation

Ideal for constant speed drug dispensing, which may be difficult to achieve with lead-screw or ball-screw systems.

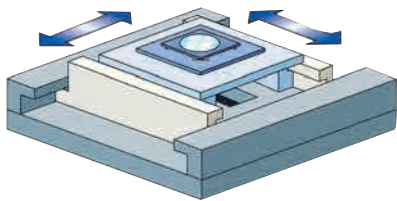

High resolution

Useful for precise micro positioning, such as those required in semiconductor equipment.

The Linear Shaft Motor can be mixed and matched to achieve the desired load thrust, based upon the complexity of the application.

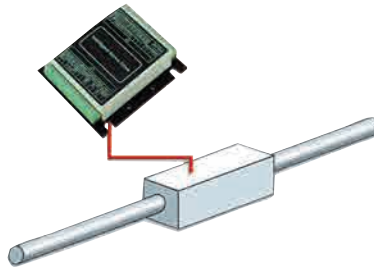

Single Drive System

This is a basic drive system. The X and Y shafts can be used to create an X-Y stage.

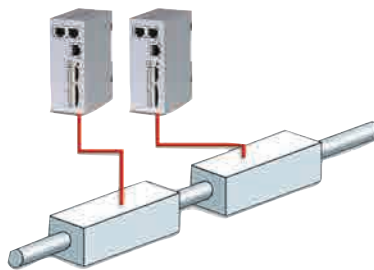

Multi-Drive System

Multiple forcers can be used with a single shaft to support complex movements required by of some applications.

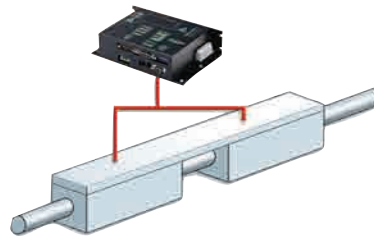

Tandem Drive System

Two or more forcers can be used on the same shaft to multiply the thrust.

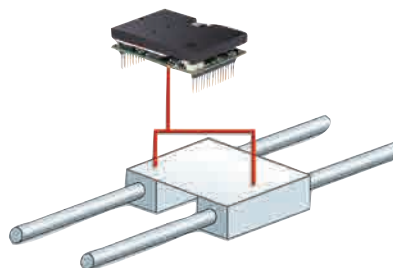

Parallel Drive System

Linear Shaft Motors can be used in parallel (two or more forcers and two or more shafts connected to the same load), to achieve large thrusts for moving heavy objects.

The design of the Linear Shaft Motor allows you to replace the standard ball-screw system with the Linear Shaft Motor and achieve higher speed and resolution. However, to achieve the highest performance with the Linear Shaft Motor system, the entire system structure must be optimized. There are various design considerations that are different from traditional servo system practices. The following are the main components needed to make a Linear Shaft Motor system, as well as factors to consider when designing a system.

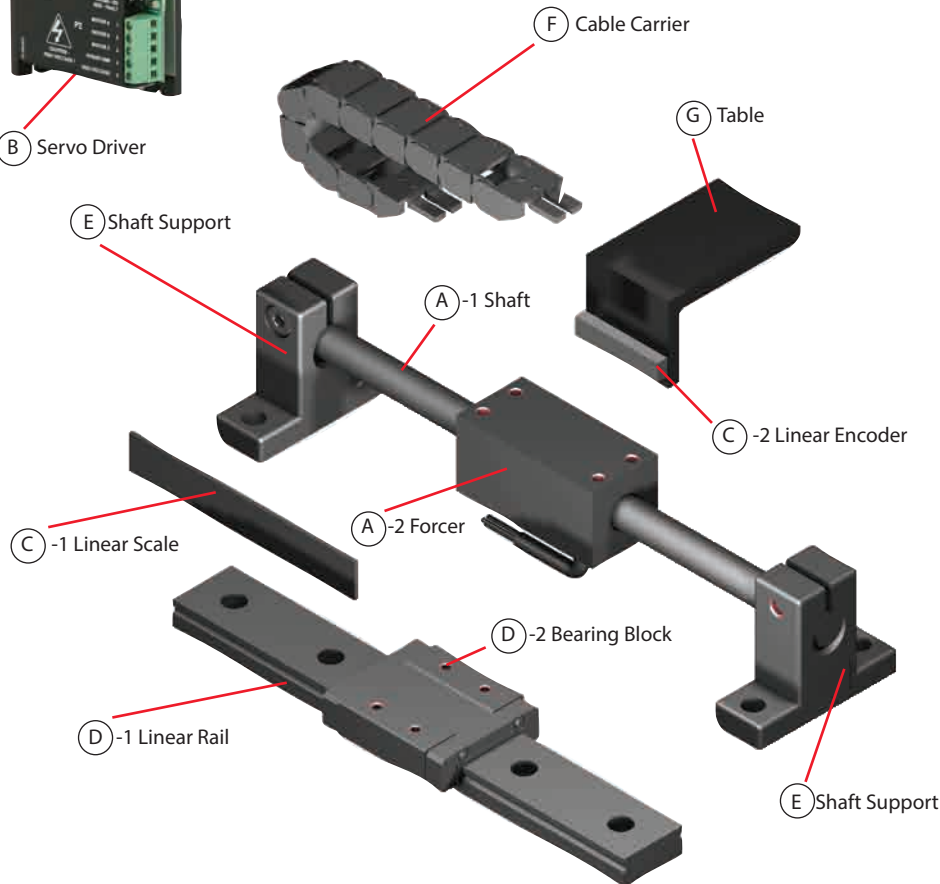

Putting Together a Linear Shaft Motor System

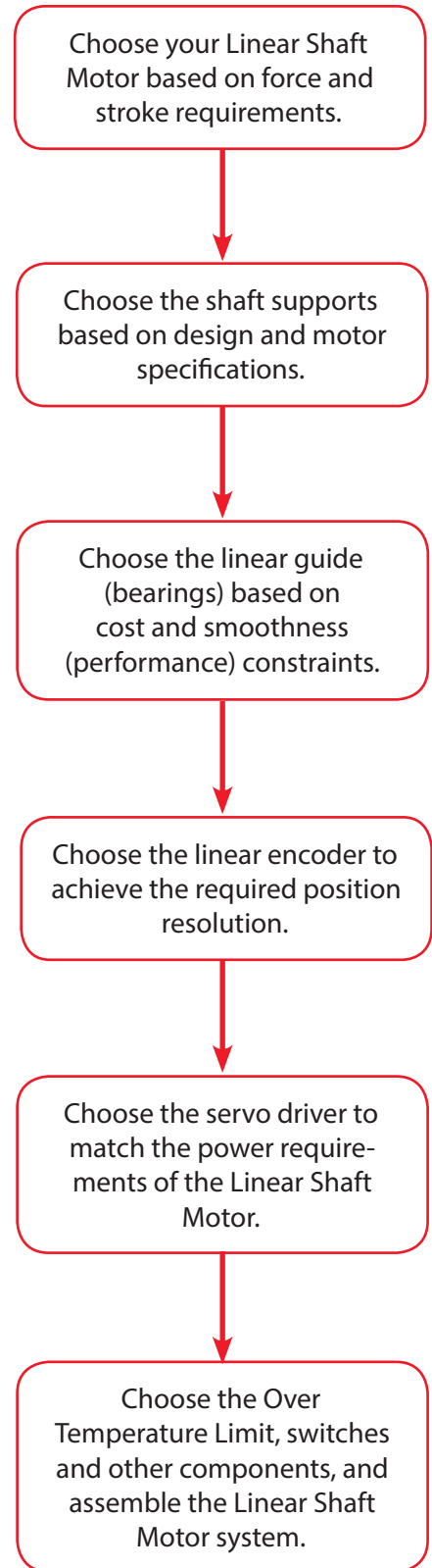

Configuring the Linear Shaft Motor

To configure a system using the Linear Shaft Motor, the following peripheral devices are required:

- A. Linear Shaft Motor
- B. Servo Driver
- C. Linear encoder (optical or magnetic)

Item D (Linear Guide) is a necessary part of a system, but consideration must be given to the application, demand specifications, environmental conditions, and whether the forcer or the shaft will be moving.

The other items, E through G, are optional and will depend on the application.

Choose the Linear Shaft Motor Based on Force and Stroke Requirements

For assistance in selecting the correct Linear Shaft Motor, check out Nippon Pulse's "SMART" tool (Linear Shaft Motor Application Resource Tool) which can be found at nipponpulse.com. The Linear Shaft Motor should be mounted as closely as possible to the center of gravity of the moving load, and to the working point of the machine.

If the motor and feedback are far apart, the machine structure and linear guide (bearings) must be of sufficient mechanical stiffness to minimize dynamic deflections of the structure. Be sure to allow clearance for ventilation and access for cleaning, repair, service and inspections. Ventilation is extremely important. Be sure the area for ventilation is not obstructed, as motors may get warm, and heat must be dissipated to prevent damage.

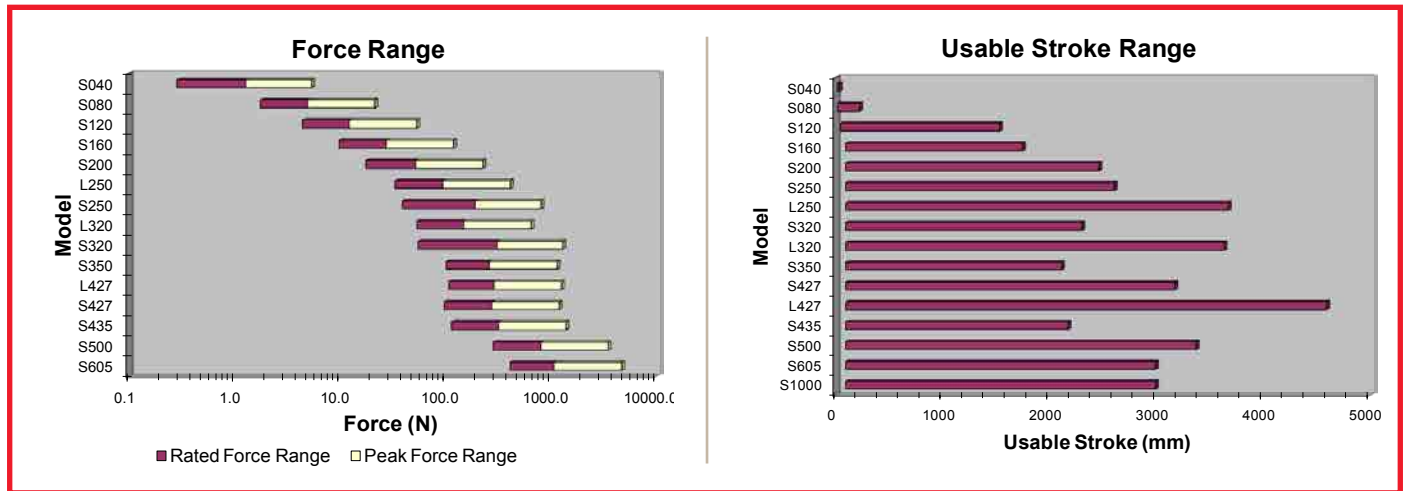

Choose the Shaft Supports Based on Force and Stroke Requirements

Select a shaft support as outlined in the data sheet of your selected Linear Shaft Motor. The shaft support is what allows longer strokes in a Linear Shaft Motor system without excessive bending of the shaft. The shaft support should not only be able to support the mass of the shaft, but also be in contact with the shaft for the specified support length. While a single shaft support will provide better security and easier alignment, another option is to space two smaller shaft supports for the specified support length. The drawing to the right illustrates these two different options.

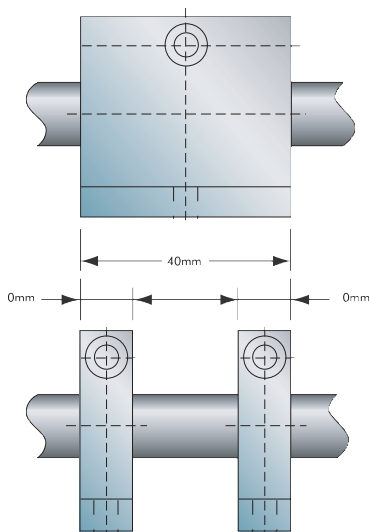

Choose the Linear Guide (Bearings) Based on Smoothness (Performance) Constraints

The linear guide (bearings) must be selected to support the moving load. Often, the linear guide is the only moving contact type component in the system. Therefore, this component requires special attention. Desirable bearing characteristics include high mechanical stiffness (for increased natural frequency) and low friction. Because the Linear Shaft Motor can provide high velocities, the speed and acceleration limitations of the bearings need to be considered. Some common bearing choices are compared in the table below. Air bearings are most desirable from the standpoint of smoothness, while mechanical slide rails are desirable due to portability.

	Slide Rails	Cam Follower	Crossed Roller	Recirculating Element	Air
Travel	⊙	⊙	●	⊙	⊙
Stiffness	●	●	⊙	⊙	⊙
Speed	●	⊙	⊙	○	⊙
Smoothness	●	⊙	⊙	⊙	○
Precision	●	●	⊙	⊙	○
Load	⊙	●	⊙	⊙	●
Cost	○	○	⊙	⊙	●

Least Desirable ● ○ Most Desirable

Choose the Linear Encoder to Achieve the Required Position Resolution

The linear encoder is one of the most important parts of your Linear Shaft Motor system. A processed signal from the linear encoder is used to precisely measure the actual position of the system. The positioning resolution, repeatability and smoothness of operation depend on the resolution of the encoder. For this reason, it is recommended you use an encoder with 1 μ m resolution or better. In addition, the maximum response speed of the encoder may limit the maximum system speed. Select a linear encoder that will supply 10 times your required resolution. Either an optical or a magnetic encoder can be used. (For more information about selecting your encoder, see Engineering Notes at the back of this booklet.)

In the case of a magnetic linear encoder, take care it is installed so the magnetic shaft does not affect the encoder. Ensure your driver supports the output mode of the selected encoder. The linear encoder should be mounted as close as possible to the working point of the machine. If the motor and feedback are far apart, the machine structure and linear guide (bearings) must be of sufficient mechanical stiffness to minimize dynamic deflections of the structure.

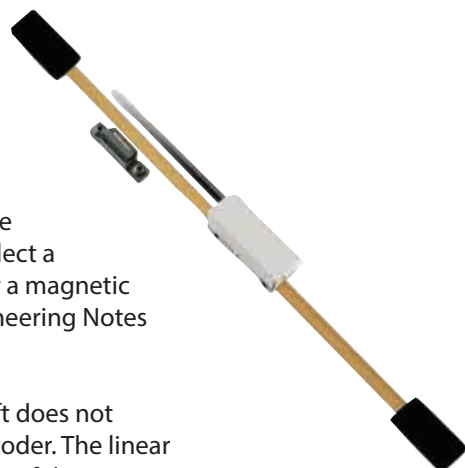

Choose the Servo Amplifier/Driver to Match the Power Requirements of the Linear Shaft Motor

Select a servo driver that can meet the power requirements of your selected Linear Shaft Motor. (For help selecting the correct servo driver, check out our **SMART** tool at nipponpulse.com, or see the Engineering Notes at the back of this booklet.) Any three-phase brushless DC servomotor driver can be used to drive the Linear Shaft Motor. In selecting a servo driver, check the method in which the magnetic position is detected.

Since the Linear Shaft Motor does not come with Hall effect sensors in its standard configuration, they will need to be added as an option, if required by your selected servo driver. If the servo driver does not require the use of Hall effect sensors, you may use the Linear Shaft Motor in its standard configuration.

Most servo drivers use peak (DC) units for voltage and current ratings, while most servomotors (like the Linear Shaft Motor) use RMS (AC) units. Please pay attention to the units when selecting a servo driver. The Engineering Notes section has formulas for converting peak values to RMS values.



Choose the OTL, Limit Switches and Other Components, and Assemble the Linear Shaft Motor System

Temperature Sensor

A temperature sensor OTL (Over Temperature Limit) will cut power to the motor should it get too hot due to overload. This can be added in series with the main power to the driver. The maximum coil temperature limit of the Linear Shaft Motor is 135°C.

Limit Switches

Limit switches can be added on either side of the load on the shaft to prevent the load from overshooting.

Cabling & Cable Carrier

The Linear Shaft Motor is typically operated with a stationary shaft and a moving forcer (it can be operated with a stationary forcer and moving shaft). With such an arrangement, you will have moving cables. A provision must be provided in the machine to carry the cables. A connector is provided with the Linear Shaft Motor to allow you to connect cables for proper flex life at the designed bend radius in the locations where the cable will move. Cables should be made in a twisted pair configuration, shielded and grounded properly to the machine base, servo driver and motor in order to reduce radio frequency interference.



Hall Effect Sensors

Hall effect sensors are devices able to sense position magnetically and provide this information to the servo driver. Some servo drivers require Hall sensor feedback for commutation. The Hall effect sensors are used by some servo drivers to obtain forcer position information relative to the shaft for commutation. Other servo drivers are able to obtain information for commutation from the linear encoder.

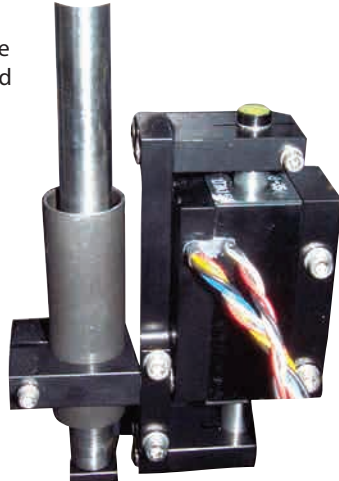

For most horizontal applications using servo drivers, there is no need for digital Hall effects. The commutation is based on a commutation table built during the tuning process, and is derived from the linear encoder. For most vertical applications, it is best to use digital Hall effects. The Linear Shaft Motor does not come with Hall effect sensors in its standard configuration; they will need to be selected as an option if required by your selected servo driver.

Because of the size of Hall effect sensors, they are not available on our 4mm Linear Shaft Motor. On the 8-20mm motors, the dimensions of your project must be expanded to include the sensors, which must be connected externally to the motor. On the 25mm series and above, the sensors fit inside the motor and no additional space is needed in your design.

Other Components

Each component must be of the lowest mass and highest mechanical stiffness possible in order to decrease settling times. Hollowed and ribbed components or honeycomb structures, along with special materials, are often utilized to achieve this. Obtaining the highest mechanical stiffness with the lowest mass requires that the linear motor be treated as an integral element to a motion system and not an add-on part.

Cooling Methods

Although the Linear Shaft Motor inherently runs cooler than other linear motors, using heat dissipation can improve the ratings of the LSM by 30 to 40 percent. Cooling methods include, but are not limited to: heat routing, heat fins (see left side of image, left), heat fans (see right side of image, left), forced air, and water cooling.

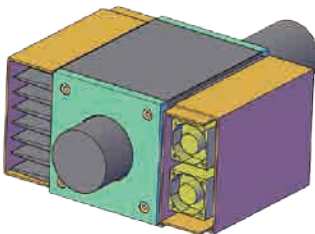

Attached to a

S080D, a 200mm x 100mm x 12mm heat sink improved the rated current by 75 percent. The same heat sink improved the rated current of a S160D by 30 percent.

Nippon Pulse sales engineers can suggest a variety of cooling methods, if cooling is necessary for your application.



At right is an example of a water-cooled S500D Linear Shaft Motor.

Linear Shaft Motor in Parallel Systems

Parallel drive systems are any application that has two or more linear motors in parallel. In parallel applications, the wires extend from the shaft on opposite sides, whereas in non-parallel applications, other motor locations are not accounted for in the wiring.

Parallel Linear Shaft Motor Design

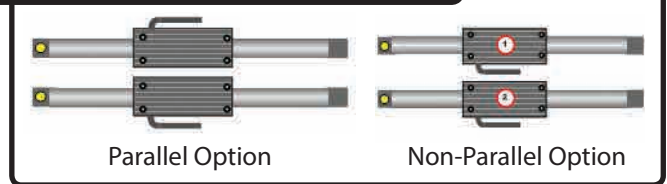

Advantages of Using Linear Shaft Motor in a Parallel Alignment

In high-precision, single-axis robot applications, truly accurate positioning is only possible when the feedback is directly in the center of mass of the work point. You also want your force generation from the motor directly in the center of mass of the work point as well; however, it is impossible to have the motor and feedback in the exact same location.

By putting an encoder in the center of mass, and using parallel Linear Shaft Motors equally spaced off the center of mass, you, in effect, are getting the desired feedback and force generation in the center of mass. You also are able to remove the heat source from the center of mass in high precision applications. This is impossible for other types of parallel drive systems, which require two sets of encoders and servo drives to provide this parallel drive functionality.

Multiple Motors, One Encoder, One Amplifier

In the past, systems may have had two different motors driving separate ball-screws, using two different controllers electronically connected together. Now that same system can be accomplished with two shaft motors, one encoder and one amplifier, as long as the stiffness in the system itself is sufficiently high.

Examples of Parallel Systems

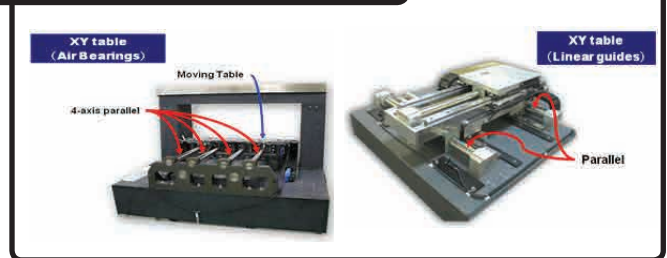

Unlimited Linear Shaft Motors Connected Together

This is also an advantage for applications where extremely high amounts of force are needed. It is possible to connect any number of Linear Shaft Motors together, thus allowing their forces to be combined.

When used in a horizontal application, Linear Shaft Motors typically will have the load attached to the forcer so as to achieve very simple and precise linear movements. In a Linear Shaft Motor system, the shaft is supported at both shaft supports and the load moves along slide rails, linear bearings, or air bearings. A linear encoder scale is attached to the guide rails to provide linear position feedback for servo control.

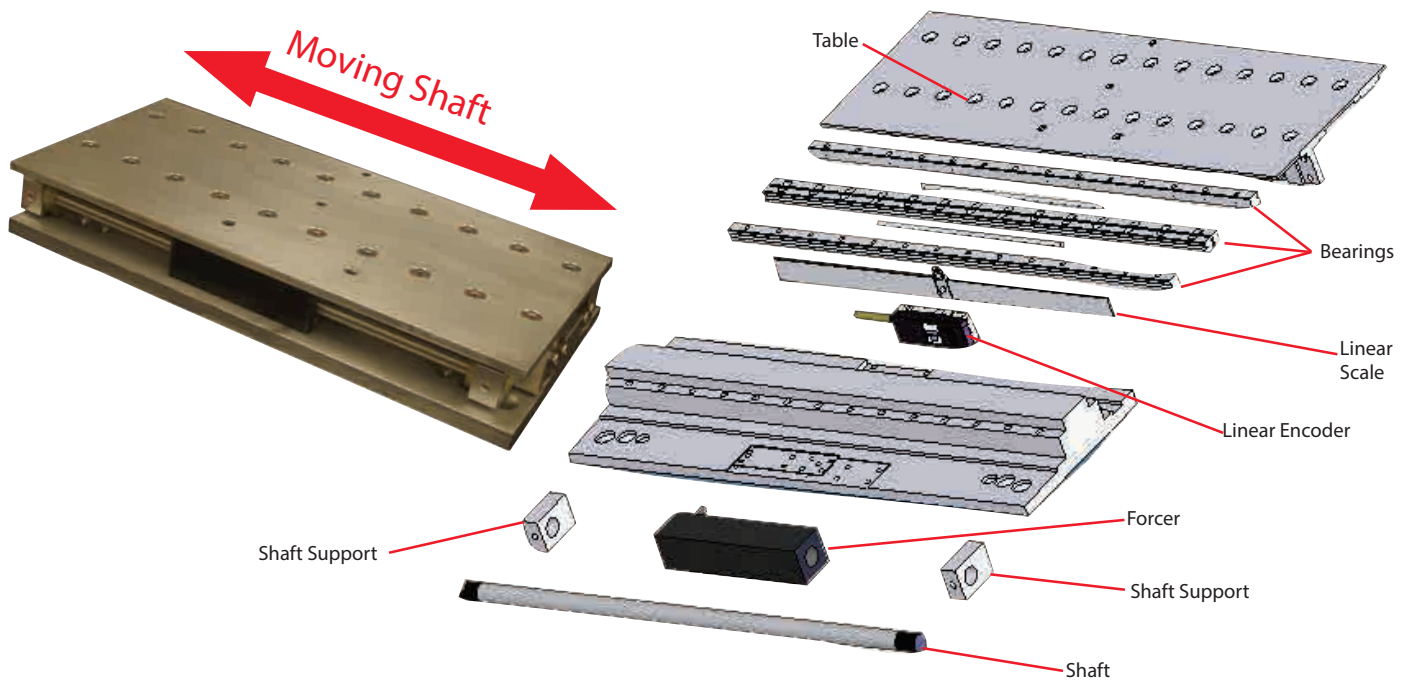
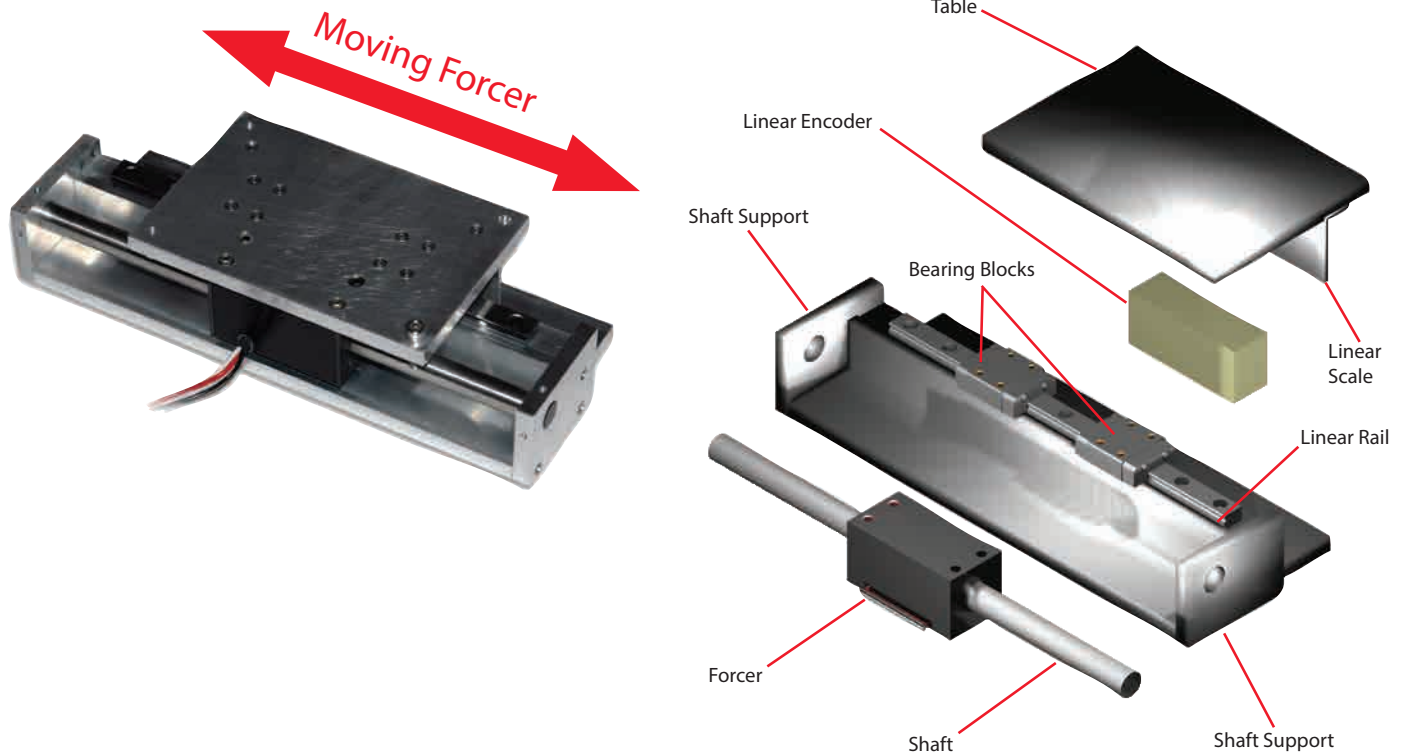

When used in a vertical application, Linear Shaft Motors typically require a counterbalance mechanism, or brake, to prevent the load from dropping in the event of a power interruption. The counter balance can also reduce the net load on the motor by supporting the load against gravity. Typical counterbalance techniques include a pneumatic cylinder, springs, or a counterweight.

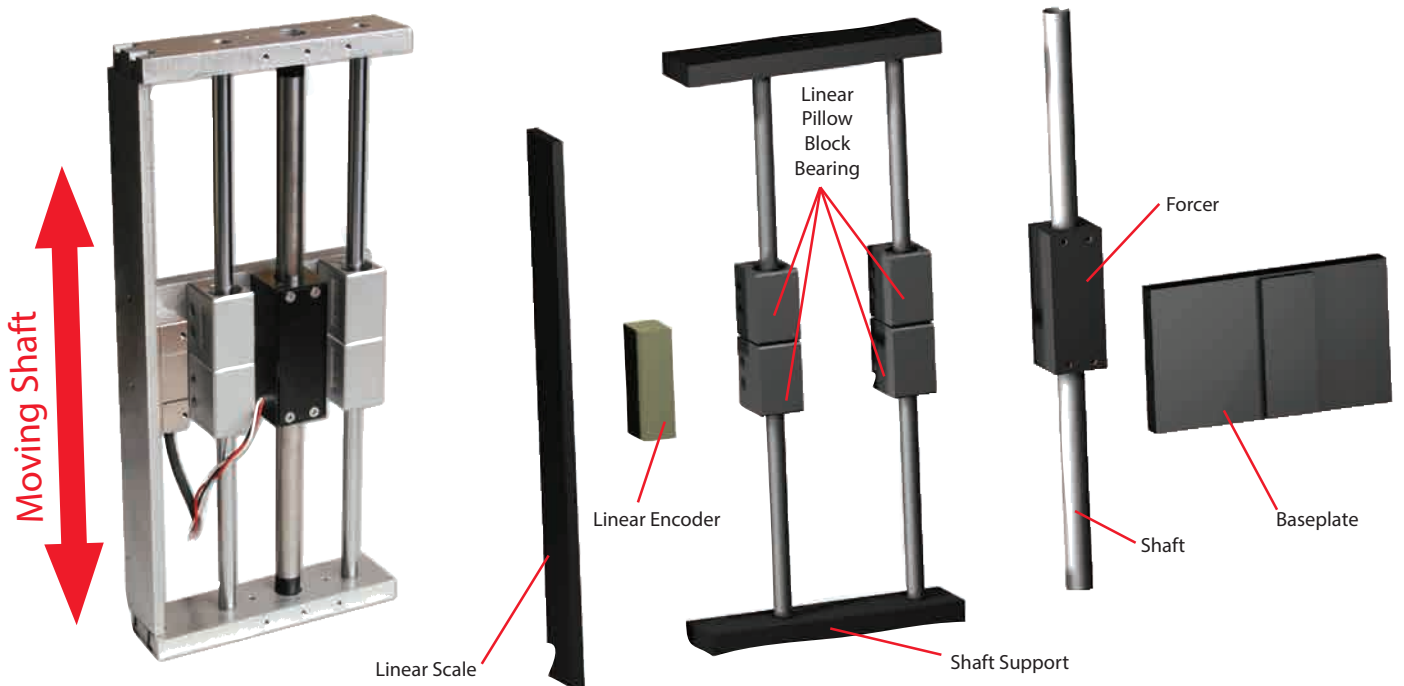
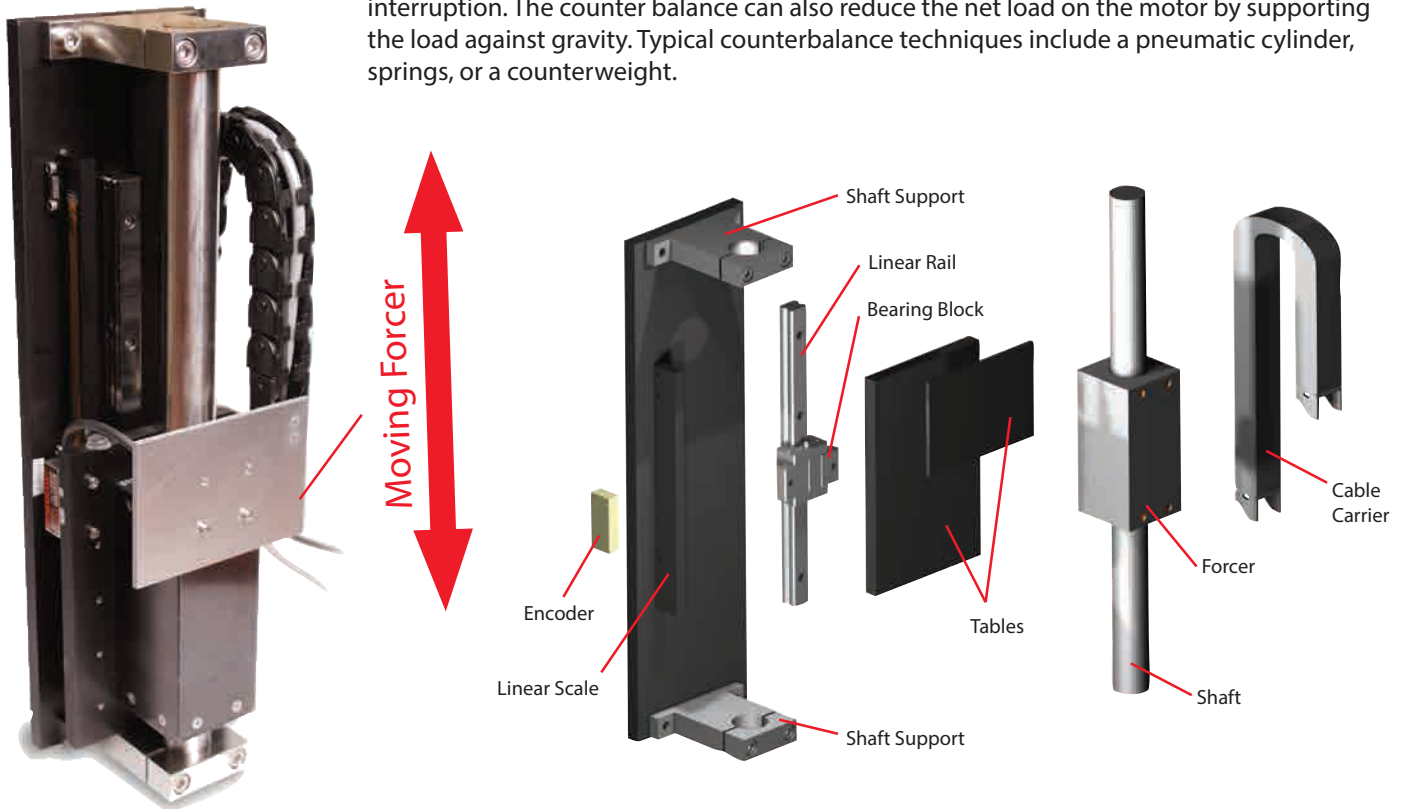

Model Number	Continuous Force N	Continuous Current A rms	Acceleration Force N	Accel. Current A rms	Force Constant (Kf) N/A rms	Back EMF V rms/m/s	Resistance Ω	Inductance mH	Forcer Length mm	Forcer Weight kg	Air Gap mm		
S080D	1.8	0.8	7.2	3.4	2.1	0.7	4.7	0.7	40	0.05	0.50	S080D	8mm shaft diameter
S080T	2.7	0.8	10.7	3.4	3.2	1.1	6.8	1.0	55	0.06	0.50	S080T	
S080Q	3.5	0.8	14	3.4	4.2	1.4	9.0	1.3	70	0.08	0.50	S080Q	
S120D	4.5	0.4	18	1.6	11	3.7	37.0	12.0	64	0.09	0.50	S120D	12mm shaft diameter
S120T	6.6	0.4	27	1.6	17	5.5	54.0	18.0	88	0.12	0.50	S120T	
S120Q	8.9	0.4	36	1.6	22	7.4	73.0	24.0	112	0.16	0.50	S120Q	
S160D	10	0.6	40	2.5	16	5.4	21.0	8.2	80	0.15	0.50	S160D	16mm shaft diameter
S160T	15	0.6	60	2.5	24	8.1	33.0	12.0	110	0.20	0.50	S160T	
S160Q	20	0.6	81	2.5	33	11	43.0	16.0	140	0.30	0.50	S160Q	
S200D	18	0.6	72	2.4	31	10	28.7	19.3	94	0.30	0.75	S200D	20mm shaft diameter
S200T	28	0.6	112	2.4	47	16	43.0	29.0	130	0.50	0.75	S200T	
S200Q	38	0.6	152	2.4	64	21	56.0	39.0	166	0.70	0.75	S200Q	
S250D	40	1.3	160	5.1	31	10.4	7.8	9.8	120	0.80	0.75	S250D	25mm shaft diameter
S250T	60	1.3	240	5.1	47	16	12.0	15.0	165	1.1	0.75	S250T	
S250Q	75	1.3	300	5.1	59	20	15.0	19.0	210	1.5	0.75	S250Q	
S250X	140	2.4	560	9.6	58	19	7.5	9.5	390	2.9	0.75	S250X	
S320D	56	1.2	226	5.0	45	15	11.0	17.0	160	1.2	1.00	S320D	32mm shaft diameter
S320T	85	1.2	338	5.0	68	23	17.0	26.0	220	1.7	1.00	S320T	
S320Q	113	1.2	451	5.0	91	30	23.0	34.0	280	2.2	1.00	S320Q	
S350D	104	1.5	416	6.0	69	23	13.8	21.8	160	1.3	1.00	S350D	35mm shaft diameter
S350T	148	1.5	592	6.0	99	33	20.2	33.0	220	1.9	1.00	S350T	
S350Q	190	2.7	760	10.8	70	23	6.9	10.9	280	2.4	1.00	S350Q	
S427D	100	3.0	400	12.0	33	11	2.7	7	220	3.0	1.65	S427D	42.7mm shaft diameter
S427T	150	3.0	600	12.0	50	17	3.9	11	310	4.2	1.65	S427T	
S427Q	200	3.0	800	12.0	67	22	5.2	15	400	5.4	1.65	S427Q	

Scaleless SL Motor: Linear Motor with Built-In Encoder

- Line Driver output
- Built in Interpolator
- Real-time Single processing
- High dynamics
- Excellent force to volume ratio
- No residual force present
- Non-magnetic aluminum housing
- Compact and robust construction
- No lubrication required
- Simple installation and configuration
- Repeat accuracy: ± 1 count ($5 \mu\text{m}$)



The Scaleless SL Motor is a tubular linear motor with a built-in Linear Encoder. The simple design features just two parts, the shaft (magnets) and forcer (coils). In addition to the coils, the forcer also contains the integrated linear encoder and hall sensors. The stainless steel shaft has the scale for the linear encoder integrated into a single unit.

The absence of residual static force and the excellent relationship between the linear force and current make these motors ideal for use in micro-positioning applications. Position control of the Scaleless SL Motor is made possible by the built-in Linear Encoder.

Scaleless SL Motor makes integration of a linear motion a very simple matter into a wide variety of applications in markets such as medical devices, laboratory equipment, instrumentation, factory automation and robotics, to name only a few.

The Scaleless SL Motor is non-contact. Since the coil completely wraps around the magnets, all the magnetic flux is efficiently used. This allows for a large 0.5 mm nominal annular air gap that is non-critical, meaning there is no variation in force as the gap varies over the stroke of the device, or if the shaft is turned in the forcer.

An integrated solution, the

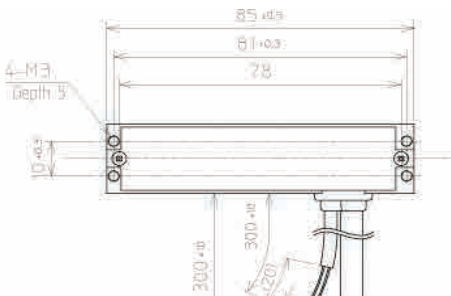
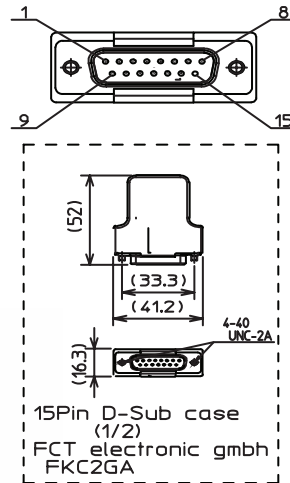
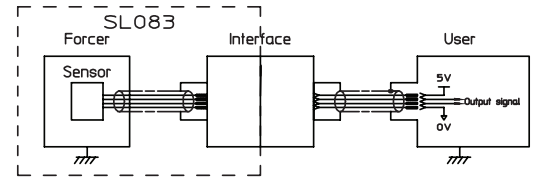

Note 1:
Cable (Motor)
UL2103- AWG24
Red : U . White : V . Black : W . Green : FG
Bending Radius : 44mm

Note 2:
Cable (Sensor)
UL20276 AWG30
Bending Radius : 60mm

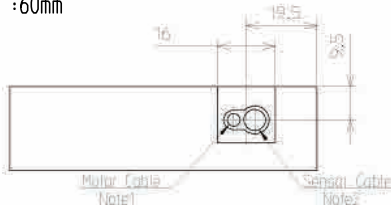

Pin	Signal
1	A+
2	A-
3	NC
4	B+
5	B-
6	U (Hall Sensor)
7	V (Hall Sensor)
8	W (Hall Sensor)
9	GND1
10	+5V VCC
11	Z+
12	Z-
13	NC
14	GND2 (Hall Sensor)
15	+5V (Hall Sensor)

*Encoder	SL083
Power Supply Voltage	DC5V $\pm 5\%$
Consumption Current	Max.25mA
Output Circuit	Line Driver
Resolution	5 μm
Signal Cycle	20 μm
Max. Travel Speed	4m/s

*Hall Sensor	SL083
Power Supply Voltage	DC5V $\pm 5\%$
Consumption Current	Max.12mA
Output Circuit	Open Collector (24V, Max.20mA)

Specs	SL083
Continuous Force	2.9N
Continuous Current	0.9Arms
Acceleration Force	11.5N
Acceleration Current	3.6Arms
Force Constant	3.2N/Arms
Back EMF	1.1V/m/s
Resistance	6.8 Ω $\pm 5\%$
Inductance	1.03mH $\pm 5\%$
Max Phase Temp.	80° C (at case)
Magnetic Pole Pitch	30mm (N-N)
Mass	Max.130g

*Encoder and Hall Sensor power supply voltage are internally isolated

SS Series Linear Shaft Motor

The SS series Linear Shaft Motors have smaller sized forcers than other standard Linear Shaft Motors. In this series, the size of the motor coil in the forcer has been dramatically reduced, which makes this series perfect for compact applications. The SS series forcer measures 50mm in length, and multiple forcers can be added to a single shaft.

Model Number	Continuous Force N	Continuous Current A rms	Acceleration Force N	Accel. Current A rms	Force Constant (Kf) N/A rms	Back-EMF V rms/m/s	Resistance Ω	Inductance mH	Forcer Length mm	Forcer Weight kg	Air Gap mm
L250SS	17	1.3	69	5.1	13	4.5	6.5	11	50	0.43	2.0
L250DS	29	1.1	118	4.3	28	9.2	13	19	80	0.72	2.0
L250TS	44	1.0	176	4.2	42	14	19	28	110	1.0	2.0
L250QS	55	1.0	220	3.9	57	19	25	37	140	1.4	2.0
L320SS	19	1.7	75	6.9	11	3.6	3.6	5.1	50	0.44	2.5
L320DS	33	1.5	132	6.0	22	7.3	7.1	7.8	80	0.68	2.5
L320TS	48	1.5	193	5.9	33	11	11	12	110	0.98	2.5
L320QS	59	1.3	235	5.2	45	15	14	15	140	1.2	2.5
L350SS	24	2.0	95	7.8	12	4.0	2.7	2.9	50	0.34	3.0
L350DS	43	1.8	170	7.3	23	7.7	5.3	4.4	80	0.56	3.0
L350TS	55	1.6	222	6.4	35	12	7.9	6.7	110	0.78	3.0
L350QS	74	1.6	298	6.4	47	16	11	8.7	140	1.0	3.0

Linear Shaft Motor Part Numbering Guide (SS Series)

Shaft Size (D)

- 250
- 320
- 350

XX Shaft diameter in mm *10

Forcer Size (A)

X

Blank Standard
_S Alternate Winding
Assigned by factory based on customer needs

Alt. Winding

XX

Usable Stroke

XXXXst

XX Usable stroke in millimeters only needed if ordering shaft

Options

XX

Blank Standard
FO Forcer Only
SO Shaft Only

Options

XX

WP Waterproof
HA Digital Hall Effect
CE CE type motor
FG Frameground
only needed if ordering forcer

of Forcers

XX

Two or more forcers (only for SS series)

SS Single winding small forcer
DS Double winding small forcer
TS Triple winding small forcer
QS Quadruple winding small forcer

Usable Stroke is = $L - (L2 * 2) - (A * \# \text{ of forcers})$

Example: For a L320SS-2500st-05
Usable stroke = 2500
L = 2950
L2 = 100
A = 50
of Forcers = 5
Usable stroke = $= 2950 - (100 * 2) - (50 * 5)$
 $= 2950 - 200 - 250$
 $= 2500$

Part Numbering Example
L350SS-1500st-03: Large air gap, 35mm shaft diameter, single winding, small forcer, stroke of 1500mm, three forcers

Common Motion Profile Formulas

Triangular Profile 1/2, 1/2

Accelerate to speed and decelerate back to original speed or zero, rest and repeat the process as needed. This is very simple and is common in applications such as pick & place.

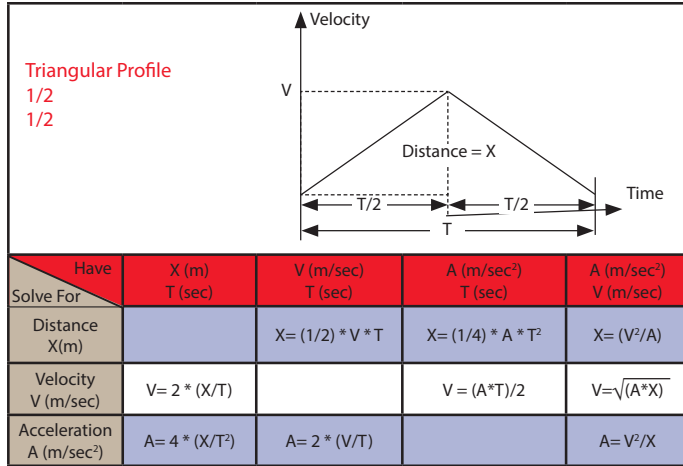

Trapezoidal Profile

Accelerate to constant speed, travel at that constant speed, and then decelerate back to original speed of zero. This is common in applications such as scanning inspection. There are two types, the 1/3 Trapezoidal Profile and the Variable Trapezoidal Profile.

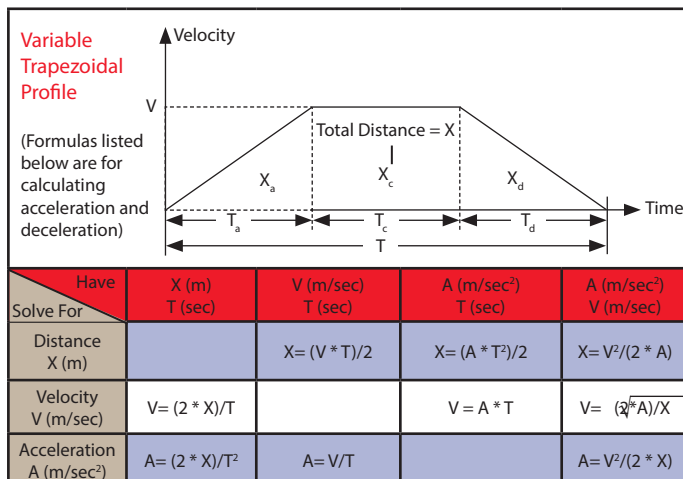
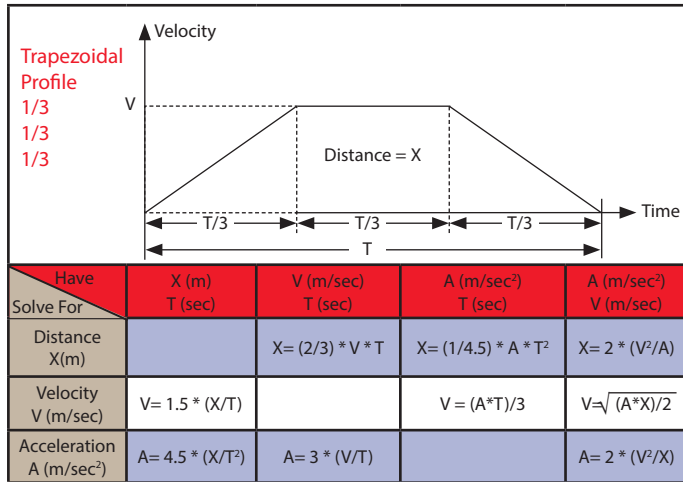

Useful Formulas

General Formulas

Acceleration G $ACCG = A (m/sec^2)/9.81$
 Gravity $g = 9.81$
 Friction Coefficient $(FC) = M2/M1$, M1 being the mass of the load to be moved, and M2 being the amount of force required to move the mass.

Voltage $V = I * R$
 Current $I = V/R$
 Resistance $R = V/I$

Voltage and Current RMS vs. Peak

RMS (AC) $Peak * 0.707$
 Peak (DC) $RMS * 1.414$

Examples:

	Voltage	Resistance	Current
RMS Values	5	25	0.2
Peak Values	3.535	25	0.1414

Please ensure your units remain constant when calculating RMS or Peak Values.

Encoder Formulas

Encoder Resolution $Er = \frac{Scale\ Pitch}{(4 * Interpolation)}$

Enc. Output Freq. (A-B Phase) $E_{OF} = \frac{Velocity * 10^6}{(4 * Encoder\ Resolution)}$

Enc. Output Freq. (Sine-Cosine) $E_{OF} = \frac{Velocity * 10^6}{(Scale\ Pitch)}$

Amplifier/Driver Sizing Formulas

Voltage due to Back EMF $V_{BEMF} = Back\ EMF * Velocity$

Voltage due to R * I $V_{ri} = 1.225 * Resistance * Peak\ Current$

Voltage due to Inductance $V_L = \frac{7.695 * Velocity * Inductance * Peak\ Current}{Magnetic\ Pitch}$

Min. Bus Voltage needed $V_{bus} = 1.15 * \sqrt{(V_{bemf} + V_{ri})^2 + V_L^2}$

Peak Current (rms value) $I_{prms} = Peak\ Current * 1.2$

Continuous Current (rms value) $I_{Crms} = Continuous\ Current * 1.2$

These formulas add a 20 percent safety margin for current and a 15 percent safety margin for voltage.

Linear Shaft Motor Selection Guide

One of the most straight-forward tasks in the design of a linear motion system is to specify a motor and drive combination that can provide the force, speed and acceleration required. This is often the most overlooked aspect of the linear motion system design, making the motor the most costly part of the system, not only from the perspective of the initial cost, but also in relation to service maintenance and energy.

The unique properties of the Linear Shaft Motor make its sizing for applications slightly different than that of other liner motors. Nevertheless, the proper sizing of a Linear Shaft Motor is rather straight-forward. Nippon Pulse provides the SMART sizing software to assist in the selection of a proper motor and drive combination for your mechanical design. Please use the following chart to assist in organizing the operation conditions for your system.

Item	Symbol	Unit	Notes	Examples
Load mass	M_L	kg	Mass of the moving part of your system less the mass of the motor.	Example: Table, Encoder
Load (thrust) Force	F_L	N	Thrust Force is added to all segments of the motion profile. This is in addition to force needed to overcome mass, acceleration and friction.	Example: As the motor moves, it needs to maintain 10 lbs of force on an object.
Run (pre-load) Friction	F_r	N	Pre-load Force is considered in all moving segments of the motion profile. Keep in mind all external forces that disturb the movement.	Example: Cable Chain, Bearing wipers, Preloaded Guide, springs
Moving Motor Mass	M_c	kg	If you are not sure which motor you are going to need, start with a value of 1/10 of load mass.	
Friction coefficient	μ			
Incline Angle	α	$^\circ$	0° is Horizontal while 90° is Vertical	
Available Voltage	V	Vac		
Available Current	A	Arms		
Max Allowable temperature		$^\circ\text{C}$		

Next, define what movements your system will be making using the following chart for assistance:

Item	Symbol	Unit	Notes
Stroke	X	mm	<p>Note: This application note walks you through sizing with only one segment. It is recommended for the best sizing of a Linear Shaft Motor, a complete cycle should be used for sizing. Stroke out and back. The SMART sizing software allows for sizing with up to six segments.</p>
Velocity	V	m/s	
Acceleration time	T_a	s	
Continuous time	T_c	s	
Deceleration time	T_d	s	
Settling time	T_s	s	
Waiting time	T_w	s	

1. Calculations for Load Condition

The chart shown here helps to calculate a load force. The frictional load of the linear guide and the resistance force of the cable carrier (FC) are run friction and treated as pre-load force. For your initial calculations, it is suggested you use 1/10 the load mass, as the value for Forcer mass (MC).

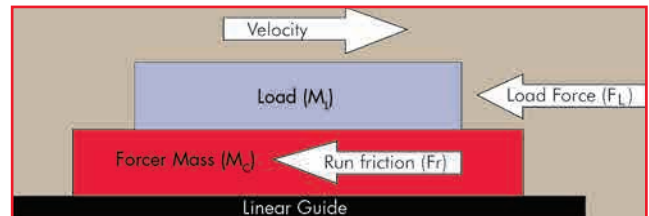

2. Calculations for Required Thrust - You will need to calculate a thrust value for each section of the motion profile. In these equations, "μ" is the coefficient of friction on the guide. "g" is as the acceleration of gravity. $g = 9.81 \text{ m/sec}^2$. "α" is the angle of incline. For vertical or incline moves use F_r for moves against gravity and F_{rd} for moves with gravity.

3. Temporary Selection - The largest thrust value calculated in section 2, must be less than peak thrust of the selected Linear Shaft Motor. It is good practice to add 20 to 50% to the peak thrust as a safety margin. Please note that the peak thrust of the Linear Shaft Motor may vary with operation speed.

F_1	Force (Inertia)	$F_1 = (M_L + M_c) * (V / T_a)$	
F_f	Force (Friction)	$F_f = (M_L + M_c) * g * [\sin(\alpha) + \mu * \cos(\alpha)] + F_r$	
F_{fd}	Force (Friction) down	$F_{fd} = (M_L + M_c) * g * [\sin(\alpha) + \mu * \cos(\alpha) * -1] + F_r$	
F_1	Acceleration force	$F_1 = F_i + F_L + F_r$	Inertia force + external force
F_2	Constant velocity force	$F_2 = F_L + F_r$	load of external force
F_3	Deceleration force	$F_3 = F_i - (F_L + Fr)$	inertia force - external force
F_4	Dwell force	$F_4 = (M_L + M_c) * g * [\sin(\alpha)] + FL$	

4. Confirm MC (forcer mass) is smaller than the value used in section 1. If it is larger, please return to section 1 to recalculate using the new MC value.

5. Confirm Effective thrust (F_{eff}) - Please confirm that effective force (F_{eff}) is less than the continuous rated force (F_{rated}) of the motor plus a safety factor (SF) of 30% to 50%.

6. If the effective force (F_{eff}) is larger, please select a new motor where the rated force (F_{rated}) is met in the equation.

$$F_{eff} = \sqrt{\frac{(F_1^2 * t_1) + (F_2^2 * t_2) + (F_3^2 * t_3)}{t_1 + t_2 + t_3 + t_4 + t_5}} < SF_{rated} + SF$$

Nippon Pulse SMART (Shaft Motor Application Resource Tool)

Nippon Pulse offers the Linear Shaft Motor Application Resource Tool (SMART) to assist in determining the proper Linear Shaft Motor. It requires Microsoft Excel 98 or newer. SMART is part of the LSM design toolkit available at nipponpulse.com. Now with relative price comparison!

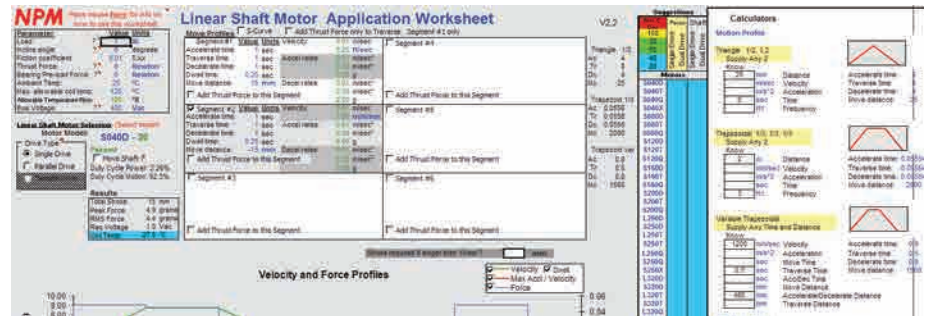

Motor Sizing Example

Let's assume you want to move horizontally a mass of 6kg point-to-point over a distance of 100 mm (X) in 160 msec, including settling time (T_m) to +/- 1 micron. Total travel is 400mm, and a dwell time of 200msec is needed after each move.

Move Profile

We will assume an estimated settling time of 10msec (T_s).

The move cycle time (T_c) is 160 + 200 = 360msec

Using previous move formula:

$$T \text{ (msec)} = T_m - (T_s)$$

$$T \text{ (msec)} = 160 - 10 = 150\text{msec}$$

We will assume an efficient trapezoidal profile (1/3, 1/3, 1/3)

Acceleration needed here (see previous move formula):

$$A = (4.5) * (0.1 * 0.15^2)$$

$$A = 20\text{m/sec}^2 \text{ (about } 2 \text{ "g")}$$

$$V = (1.5) * (0.1 / 0.15)$$

$$V = 1\text{m/sec}$$

The acceleration and deceleration time becomes (150/3) = 50msec

The time at constant speed is (150/3) = 50msec

We can estimate the acceleration force of the load only (see previously mentioned formula) at 2g*9.81*6kg = 117N.

Based on this we can select **S350T** (peak force = 592N, continuous force = 148N) assuming a coil mounting plate of 1kg.

Total moving mass: 6kg (load) + 1kg (plate) + 1.9kg (coil mass) = 8.9kg

Coil resistance = 20.2ohm, Coil cycle constant 99N/Am, Thermal Resistance 2.4°C/W, Back Emf 33Vp/m/sec,

Inductance p-p 33mH, Electrical cycle length 120mm

We assume a good set of linear bearings with μ=0.005 and 20N of friction.

Friction Force: $F_f \text{ (N)} = 8.9 * 9.81 * [\sin(0) + 0.005 * \cos(0)] + 20 = 20.4\text{N}$

Inertial Force: $F_i \text{ (N)} = 8.9 * 20 = 178\text{N}$

Total Acceleration Force: $F_1 \text{ (N)} = 178 + 20.4 = 198.4\text{N}$

Total Constant Velocity Force: $F_2 \text{ (N)} = 20.4\text{N}$

Total Deceleration Force: $F_3 \text{ (N)} = 178 - 20.4 = 157.6\text{N}$

Total Dwell Force: $F_4 \text{ (N)} = 0\text{N}$

RMS Force: $F_{rms} \text{ (N)} = \sqrt{[(198.4^2 * 0.05) + (20.4^2 * 0.05) + (157.6^2 * 0.05) / 0.36]}$

$$F_{rms} \text{ (N)} = 94.7\text{N}$$

RMS Current: $I_{ca} = 94.7 / 99 = 0.96 \text{ Amp rms}$

Peak Current: $I_{pa} = 198.4 / 99 = 2 \text{ Amp rms}$

Motor Resistance Hot: $R_{hot} = 20.2 * 1.423 = 28.7\Omega$

Voltage due B EMF: $V_{bemf} = 33 * 1 = 33\text{Vac}$

Voltage due I*R: $V_{ir} = 1.225 * 28.7 * 2 = 70.32\text{Vac}$

Voltage due Inductance: $V_L = 7.695 * 1 * 33 * 2 / 120 = 4.23\text{Vac}$

Bus Voltage needed: $V_{bus} = 1.15 * \sqrt{[(33 + 70.3)^2 + 4.23^2]} = 118.8\text{Vac}$

Item	Symbol	Value	Unit
Load Mass	M _L	7	kg
Load (Thrust) Force	F _L	0	N
Run (Pre-Load) Friction	F _r	20	N
Moving Motor Mass	M _c	1.9	kg
Friction Coefficient	μ	0.005	
Incline Angle	∞	0	°
Available Voltage	V	120	Vac
Available Current	A	7	Arms
Max Allowable Temperature		110	°C

Item	Symbol	Value	Unit
Stroke	X	100	mm
Velocity	V	1	m/s
Acceleration Time	T _a	0.05	s
Constant velocity force	T _c	0.05	s
Deceleration Time	T _d	0.05	s
Settling Time	T _s	0.01	s
Waiting Time	T _w	0.2	s

For More Information

For assistance in sizing and selecting a motor, a detailed step-by-step guide is available as part of the Linear Shaft Motor Design Toolkit on our website, nipponpulse.com. You can also call to speak with one of our sales engineers for personalized recommendations for your specific application.

About Nippon Pulse

Since 1952, Nippon Pulse has provided a wide array of motion control solutions, including industry-leading stepper motors, the innovative Linear Shaft Motor, controllers, drivers and networks. With several customization options, we provide products that can be utilized in an extensive number of applications.

Your Partner in Motion Control

At Nippon Pulse, we approach customer applications from an overall project standpoint, enabling us to provide the best electro-mechatronic solutions that will help you design and build your motion control systems. Our system engineering services include complete design, engineering and manufacturing. We have experience working with applications that include various pick-and-place machines, large scale sorting and distributing systems, biomedical handling equipment, healthcare products, and more. Our sales engineers have extensive product knowledge and can help you determine the best solution for your particular motion control application.

From standard industrial sectors to high-level electronics, Nippon Pulse optimizes development and manufacturing, and provides many high-performance product groups. In order to provide the most efficient products and facilities, we are always conscious of a smooth flow from planning to design and manufacturing. This efficient flow makes it possible to create a wide variety of products that meet customers' needs.



INDUSTRIES WE SERVE

- Automation
- Bio-Medical & Medical
- Equipment Manufacturing
- Instrumentation
- Machine Tooling
- OEM
- Packaging
- Pharmaceutical
- Photonics
- Semiconductor

It is essential that we provide products that exceed customer expectations, so they are able to use them with complete confidence. Maintaining excellent quality while ensuring a stable supply chain for each of our products is achieved by thorough quality-control methods. These methods guarantee reliability above industry standards.

Whether we provide entire systems or just one motor, ensuring those products have exceeded expectations is part of our methodology. In-depth communications with the customer from the design phase through delivery and beyond installation guarantees this.

We strive to provide you with the best possible products and process through communication, world-class support, and reliable products.

In-House Model Shop

The Nippon Pulse model shop provides quick turnaround on prototype requests for our tin-can stepper motors. Most requests can be shipped within 24 hours, so you can test the product in your application before committing to a purchase order. Nippon Pulse sales engineers work closely with you to understand your project so we are able to suggest the best solution possible and get a high-quality prototype to you as quickly as possible. Nippon Pulse offers the flexibility to ship just one piece to make sure our product is the correct fit for your project. In addition to the tin-can type stepper motors, we have various linear step motors, hybrid motors, controllers and drivers in stock for quick prototyping.



The Nippon Pulse Advantage

For more than 60 years, Nippon Pulse has built state-of-the-art products based on a solid foundation of advancing technology and thorough product research.

Nippon Pulse faithfully provides these high-quality products to a wide range of industries in North and South America and Europe. We have established ourselves as a leader in stepper motor, driver and controller technology while introducing innovative products, such as the Linear Shaft Motor and Motionnet®. At Nippon Pulse, we believe that by bringing products to market that meet the customers' requirements and exceed expectations, we contribute to the progression of technology and its positive impact on our society.

We have representatives throughout North and South America and Europe to assist customers directly. Limited quantities of stock on standard motors and electronics are available to allow faster response to customer needs. In addition, Nippon Pulse has a model shop in its North American headquarters for quick turnaround on custom prototypes and special orders. Our mission is to faithfully create the new products sought by our customers and to contribute to the development of society from a global viewpoint.

When you choose a Nippon Pulse motor, driver, controller, network or stage, you're doing more than just buying a quality product: you're benefitting from what we call the Nippon Pulse Advantage. This includes superior prototyping, complete system engineering, proper compliance and certification according to international guidelines, exceptional tailoring to your needs, and unmatched support.

A wholly owned subsidiary of Nippon Pulse Motor Co., Ltd., Nippon Pulse America is headquartered in Radford, Va.



NPM

4 Corporate Drive
Radford, Va. 24141 USA
p: 1-540-633-1677 • f: 1-540-633-1674
npmeurope.com • info@nipponpulse.com



FS 645238

EMS 645237

Nippon Pulse Representative Information

ALCYON

ÉLECTRONIQUE

RD 11 – BP20 – 78650 Beynes – France

Tel : +33 (0) 134 947 700

info@alcyonelectronique.fr

Fax : +33 (0) 134 875 340

www.alcyonelectronique.fr