

6241 Bellows Footswitch/Palm Switch

Multi-pedal version

herga

Technology Ltd

- Multi-pedal footswitch, 1-8 pedal options
- Compact for discrete placement beneath equipment, or for storage
- Robust but aesthetic design
- Soft touch buttons with a light operating force
- Ideal for motion control applications

CE **UL** [®] **US**



Reference dimensions

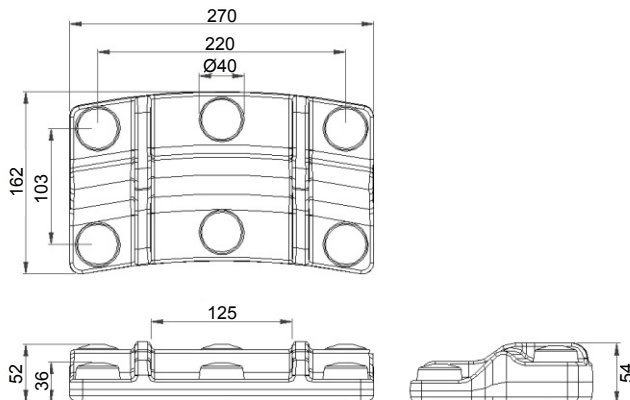

General specifications

Standards/approvals	UL 60601-1 File No. E 207181, IEC 60601-1	Operating temperature range	+10°C to +50°C
Degree of protection	EN 60529 IP67 (IP68 upon request)	Body material	Thermoplastic
Connection method	Stripped cable cores or connector of your choice, straight or curly coil cable	Weight	1.0 kg
Electrical rating	50mA 24V DC	Additional information	choice of colours, logos and labels available
Contact configuration	SPST N/O		

ALCYON

ÉLECTRONIQUE

RD 11 – BP20 – 78650 Beynes – France

Tel : +33 (0) 134 947 700

info@alcyonelectronique.fr

Fax : +33 (0) 134 875 340

www.alcyonelectronique.fr