

REVISIONS					
ZONE	ECN	REV.	DESCRIPTION	DATE	APPROVED
		1	ORIGINAL DRAWING	07/14/16	

- NOTES:
- USE ESD PROTECTION WHEN HANDLING PACKAGE WITH ESD SENSITIVE BAG
 - POWER VOLTAGE RANGE +7V TO +36V
 - WEIGHT: $\leq 115g$
 - FINAL FINISH: BLUE ANODIZE PER MIL-A-8625 TYPE II, CLASS II
 - SHIPS WITH HARDWARE:
 - M4 x .7 x 12mm OR 8-32 x 1/2 SCREWS
 - M83513/05-05 JACK SCREWS
 - M83513/03-B03N 15 PIN MATING CONNECTOR

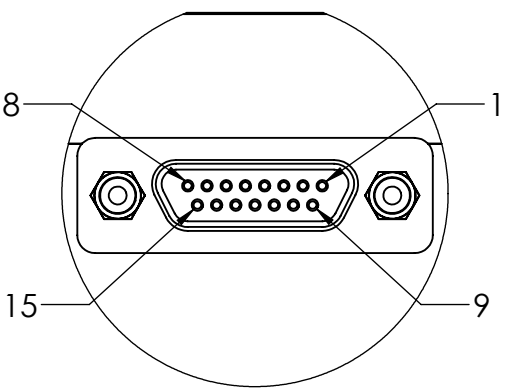

DETAIL A
SCALE 2 : 1

PIN NO.	PIN ASSIGNMENT
1	RS-485 A (+)
2	RS-485 B (-)
3	POWER GROUND
4	ANALOG/ DIGITAL INPUT (0V - 5V)
5	+7V TO +36V INPUT POWER
6	EXTERNAL SYNC INPUT (5kHz OR 1pps)
7	+5V REGULATED OUTPUT
8	SIGNAL GROUND
9	SELF TEST
10	CANBUS HIGH
11	CANBUS LOW
12	CANBUS GROUND
13	NOT CONNECTED
14	NOT CONNECTED
15	CASE

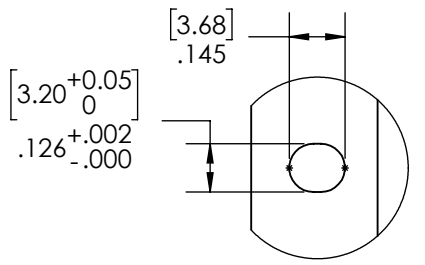
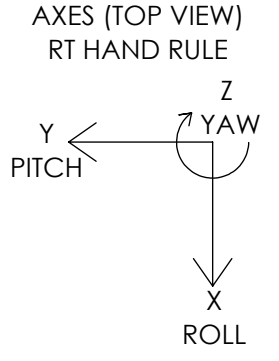

DETAIL B
SCALE 2 : 1

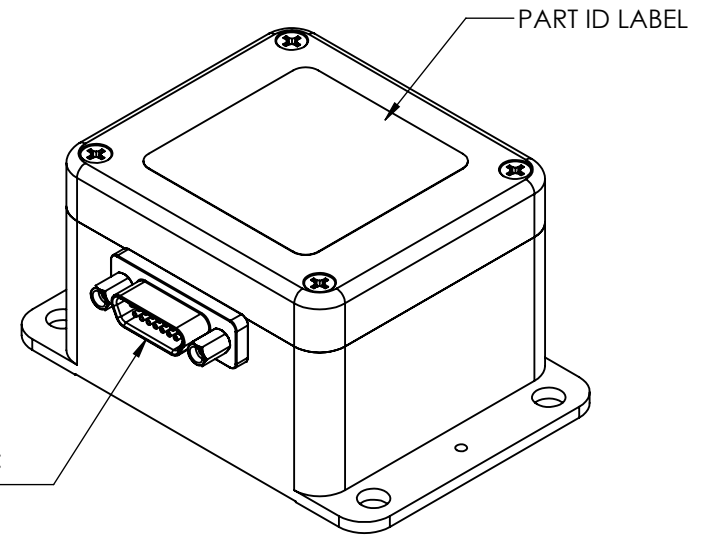
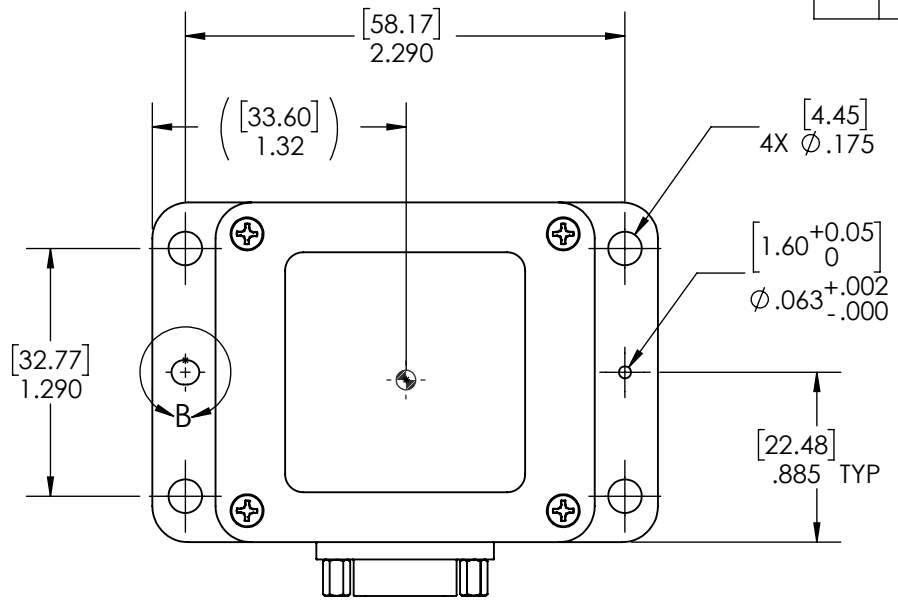

UNIT CONNECTOR:
M83513/04-BN

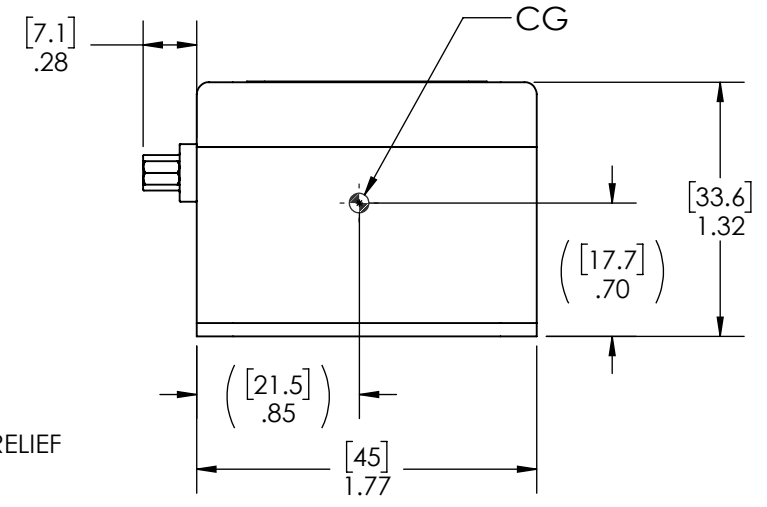
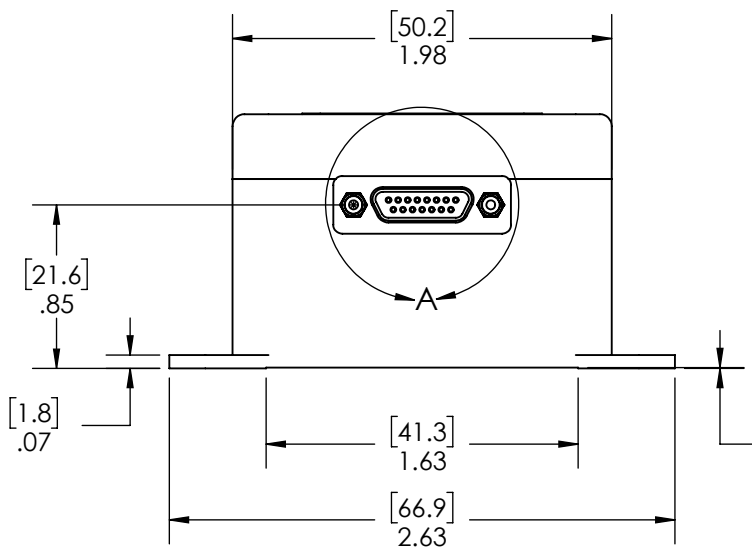

THIS DOCUMENT IS AN UNPUBLISHED WORK. COPYRIGHT 2016 GLADIATOR TECHNOLOGIES ALL RIGHTS RESERVED.

THIS DOCUMENT AND ALL INFORMATION AND EXPRESSION CONTAINED HEREIN ARE THE PROPERTY OF GLADIATOR TECHNOLOGIES AND ARE PROVIDED TO THE RECIPIENT IN CONFIDENCE ON A "NEED TO KNOW" BASIS. YOUR USE OF THIS DOCUMENT CONSTITUTES ACCEPTANCE OF THESE TERMS.

INFORMATION CONTAINED IN THIS DOCUMENT IS SUBJECT TO U.S. EXPORT LAWS AS DEFINED IN THE EXPORT ADMINISTRATION REGULATIONS (EAR) AND/OR THE INTERNATIONAL TRAFFIC AND ARMS REGULATIONS (ITAR). ILLEGAL EXPORT IS PROHIBITED.

Commercial Distribution Authorized per Commodity Classification ECCN7A994 (T-5 Countries Distribution Prohibited) Non-Technical Detail and is Non-ITAR

TYPED SIGNATURES CONSTITUTE APPROVAL. ACTUAL SIGNATURES ON FILE AT GLADIATOR TECHNOLOGIES IN SNOQUALMIE, WA



UNLESS OTHERWISE SPECIFIED		CONTRACT NO.		GLADIATOR TECHNOLOGIES SNOQUALMIE, WA	
ALL DIMENSIONS ARE IN INCHES AND () METRIC - TOLERANCES UNLESS SPECIFIED ARE:	TOL.	.XX	±.01	DRAWN	JTZ 07/14/16
		.XXX	±.005	CHECKED	MEA XX/XX/XX
FINISH:	SEE NOTES	ANGLE	±X°	MECH.ENG.	JTZ 07/14/16
INTERPRET DRAWING PER ASME Y14.100 BREAK ALL SHARP EDGES				Q.A.	KRM XX/XX/XX
				APPD.	MKC XX/XX/XX
PRECIOUS METAL INDICATOR CODE A				TITLE: LMRK65-IMU OUTLINE	
DASH NO.	NEXT ASSY DWG	TOP LEVEL APPLICATION		SIZE: B	DWG. NO. 990-LMRK65-IMU
				SCALE:	CAGE CODE: 47L11
				REV. 1	
				SHEET: 1 OF 1	