

REVISIONS					
ZONE	ECN	REV.	DESCRIPTION	DATE	APPROVED
		A	ROLLED TO PRODUCTION FROM REV 3	09/11/2017	MKC

- NOTES:
- USE ESD PROTECTION WHEN HANDLING
  - PACKAGE WITH ESD SENSITIVE BAG
  - POWER VOLTAGE RANGE: +3.8 V TO +5.5 V
  - WEIGHT: 17.5 g ±.5
  - FINISH: ANODIZE PER MIL-A-8625 TYPE II, CLASS II, BLUE
  - CHROMATE CONVERSION PER MIL-DTL-5541F, TYPE 1, CLASS 3
  - ANY UNUSED PINS MUST BE CONNECTED TO SIGNAL GROUND
  - UNIT MOUNTING SURFACE FLATNESS MAX:  $[\frac{\square}{\square}] .001 \text{ in}$   $[\frac{\square}{\square}] .025 \text{ mm}$
  - UNIT MOUNTING SCREW TORQUE: 32.5 in-oz [23 N-cm] (**MUST USE ALL 4 SCREWS**)
  - SHIPS WITH:
    - A105214-001 MATING CONNECTOR W/ 18" (46cm) FLYING LEAD AND 2X 0-80 X 5/32" PAN HEAD CAP SCREWS
    - 4X 2-56 X 3/8" SS BUTTON HEAD CAP SCREWS OR M2 X 0.4 X 6 mm SS METRIC SOCKET HEAD CAP SCREWS

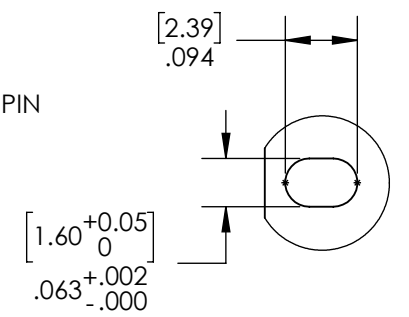
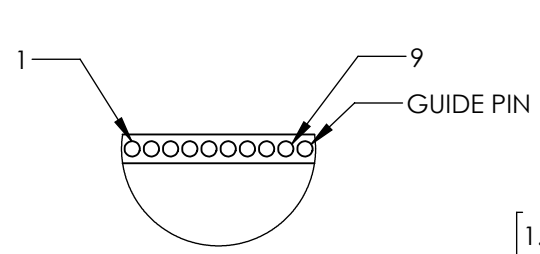
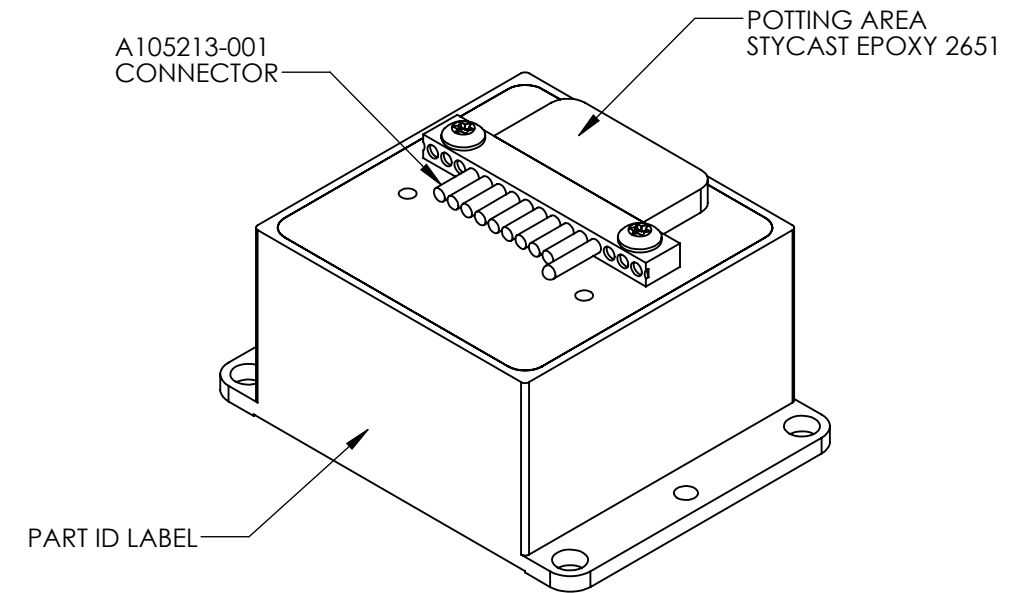
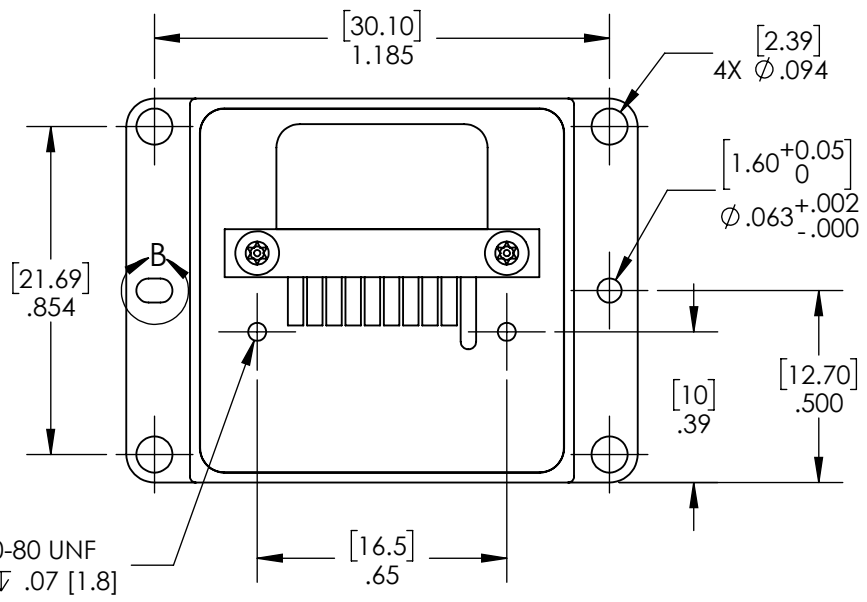
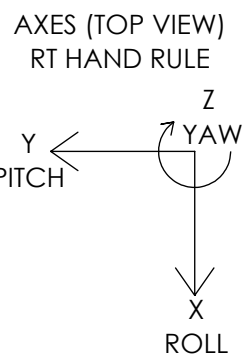

DETAIL B  
SCALE 4 : 1

= TWISTED PAIR

PIN NO.	ASSIGNMENT	COLOR
1	RS-422/485 A (+)	BLACK
2	RS-422/485 B (-)	BROWN
3	POWER GROUND	RED
4	NOT CONNECTED	ORANGE
5	+3.8 TO +5.5V MAX INPUT POWER	YELLOW
6	EXTERNAL SYNC INPUT (2.5 kHz)	GREEN
7	SIGNAL GROUND	BLUE
8	SELF TEST	PURPLE
9	CASE GROUND	GREY

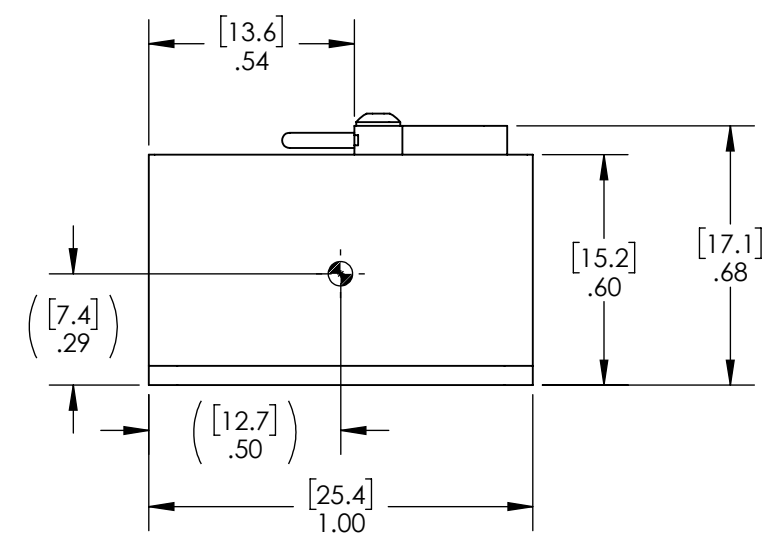
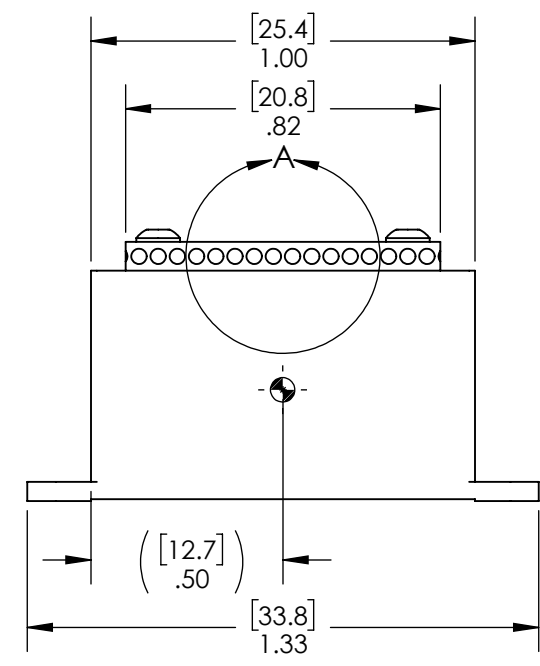

THIS DOCUMENT IS AN UNPUBLISHED WORK. COPYRIGHT 2017 GLADIATOR TECHNOLOGIES ALL RIGHTS RESERVED.

THIS DOCUMENT AND ALL INFORMATION AND EXPRESSION CONTAINED HEREIN ARE THE PROPERTY OF GLADIATOR TECHNOLOGIES AND ARE PROVIDED TO THE RECIPIENT IN CONFIDENCE ON A "NEED TO KNOW" BASIS. YOUR USE OF THIS DOCUMENT CONSTITUTES ACCEPTANCE OF THESE TERMS.

INFORMATION CONTAINED IN THIS DOCUMENT IS SUBJECT TO U.S. EXPORT LAWS AS DEFINED IN THE EXPORT ADMINISTRATION REGULATIONS (EAR) AND/OR THE INTERNATIONAL TRAFFIC AND ARMS REGULATIONS (ITAR). ILLEGAL EXPORT PROHIBITED.

Commercial Distribution Authorized per Commodity Classification ECCN7A994 (T-5 Countries Distribution Prohibited) Non-Technical Detail and is Non-ITAR

TYPED SIGNATURES CONSTITUTE APPROVAL. ACTUAL SIGNATURES ON FILE AT GLADIATOR TECHNOLOGIES IN SNOQUALMIE, WA



UNLESS OTHERWISE SPECIFIED		CONTRACT NO.		GLADIATOR TECHNOLOGIES SNOQUALMIE, WA	
ALL DIMENSIONS ARE IN INCHES AND ( ) METRIC - TOLERANCES UNLESS SPECIFIED ARE:	TOL.	.XX	±.01	DRAWN	JTZ 05/22/17
		.XXX	±.002	CHECKED	MEA 09/11/17
FINISH:	SEE NOTES	ANGLE	±X	MECH. ENG.	JTZ 05/22/17
	INTERPRET DRAWING PER ASME Y14.100 BREAK ALL SHARP EDGES			Q.A.	RCB 09/11/17
				DSGN. ENG.	RHH 09/11/17
				APPD.	MKC 09/11/17
DASH NO.	NEXT ASSY DWG	TOP LEVEL APPLICATION	PRECIOUS METAL INDICATOR CODE A	SCALE:	CAGE CODE: 47L11 SHEET: 1 OF 1

TITLE:	G300D GYRO OUTLINE	
SIZE:	DWG. NO.	REV.
B	990-G300D-100	A